



TwinFresh COMFO RA1-50-2

Single Room Total Recovery Ventilator

The Single Room Total Recovery ventilator is an easy and effective solution for rooms and smaller areas providing innovative ventilation for buildings under construction and renovation.

FEATURES

- Fresh air supply
- Heating cost savings during winter
- Reduced cooling costs during summer
- Indoor humidity control
- One TwinFresh COMFO can ventilate up to 343 sq ft
- Units can operate independently or can be wired for master-slave operation.
- Air filtration
- Anti-bacterial air treatment
- Polluted air extract
- 3 Year Warranty

BENEFITS

Pending patent on ceramic ERV core

External rotor motor on ball bearing with thermal protection ensures long life of the fans.

Plug-&-Play installation

- No special skills required
- No balancing needed
- Through the wall installation.
- Compact unit design

Multifunctional Wireless Remote Control

- Almost no maintenance required
- Washable filter and core
- MERV6 air purification
- Antibacterial treatment of ERV core and filters

Aluminum or stainless steel outer hood

- Modern design that fits any interior and exterior
- 100% corrosion proof

EC Motor

- Efficacy 5.7 CFM/W – Twice as high as the Energy Star requirement
- Whisper quiet operation, as low as 0.1 SONES

TwinFresh COMBO DESIGN

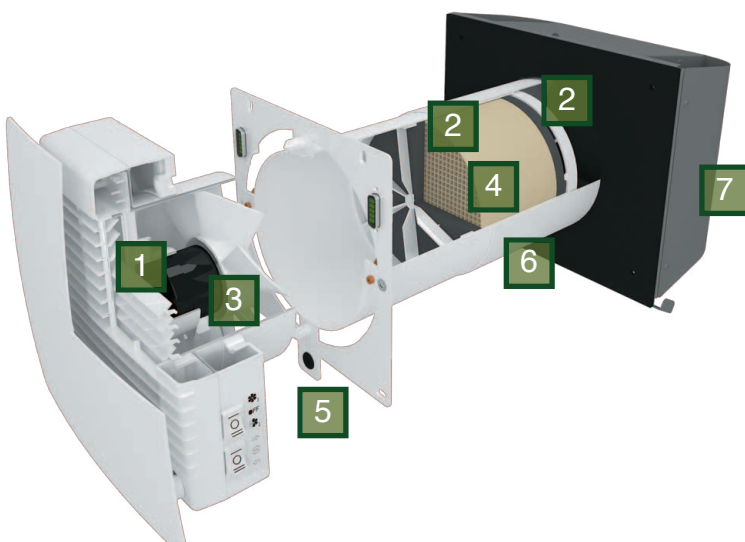

1 Front grille with automatic shutters

Modern design of the front grille makes it look great in any interior. Easy access for filter cleaning or replacement. The front grille is made of high quality snow-white ABS plastic.

2 MERV6 air filter. Antibacterial treatment

Two G3 built-in filters provide fresh air free of dust, pollen, insects.

3 Reversible axial EC fan

The latest EC-motor technology ensures low energy costs. The motor has integrated overheating protection and ball bearings for longer service life.

4 Ceramic ERV core

The ventilator includes a high-tech polymer ceramic energy accumulator with ARE 90% @ 32 F. Antibacterial treatment. No defrost needed.

5 Control

6 Telescopic Duct - diameter 6"

7 Outer hood

The exterior is constructed of aluminum covered with a special polymer coating to ensure long-lasting protection from the elements. A grill protects water and foreign objects from entering the unit.

TwinFresh COMFO RA1-50-2

Single Room Total Recovery Ventilator

OPERATION OF TwinFresh COMFO VENTILATORS

The ventilator is designed for both extract and supply ventilation with energy recovery function.

- **CYCLE I.** While warm, stale air is extracted from a room it passes through the ceramic energy core where the heat and moisture is being accumulated. After the ceramic core heats up, the ventilator automatically switches to supply mode.
- **CYCLE II.** As the clean, fresh air from outside passes through the ceramic energy core, it absorbs moisture and it warms up due to the accumulated heat. As temperature of the accumulator drops down, the fan switches to extract mode and the cycle is renewed. The ventilator changes its operation mode for supply or extract ventilation every 70 seconds.

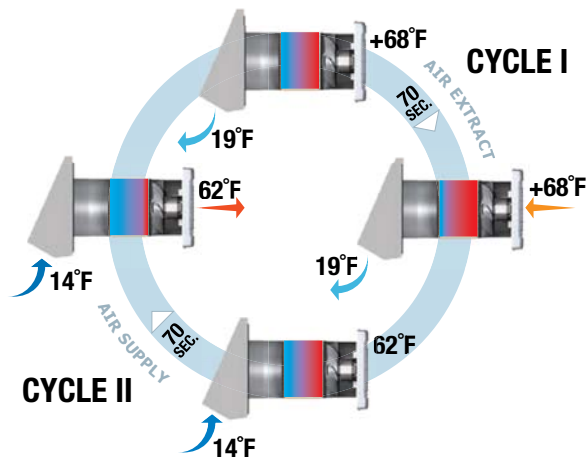

TwinFresh COMFO CONTROL AND OPERATION MODES

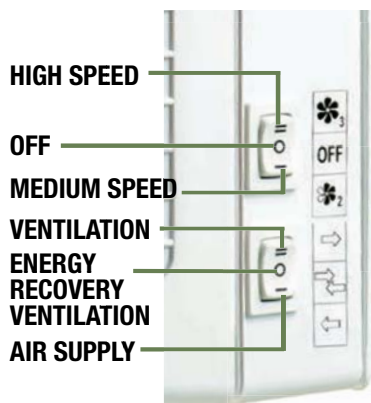

POWER Turn ventilator on/off

SPEED SWITCH

PASSIVE AIR SUPPLY
The louvre shutters are opened, but the fan stands still.

VENTILATION
All the ventilators in the network operate in permanent air extract or air supply mode.

HUMIDITY CONTROL MODE SELECTION

The ventilator automation enables setting one of three humidity set points (45, 55 or 65%). The ventilator will operate to increase or decrease the indoor humidity level to maintain comfortable environment for you.



NIGHT MODE
The ventilator is switched to low speed on a signal from built-in light sensor.

SUPPLY MODE
The fan continuously supplies fresh air to the room.

VENTILATION WITH ENERGY REGENERATION
The ventilator switches from supply and extract modes and vice versa in a set time period to enable the transfer of heat energy in winter and control of moisture in summer.

PERFORMANCE SPECIFICATIONS

MODEL	SPEED	VOLTAGE (V)	POWER (W)	CURRENT (A)	AIR CAPACITY (CFM)	ROTATION SPEED (MIN-1)	SONES	EFF @32°F	TRANSPORTED AIR TEMP (°F)	INGRESS PROTECTION RATING
RA1-50-2	1	120/60 HZ	3.8	0.024	8	610	0.1	91%	FROM -13 UP TO 122	IP 45
	2		3.96	0.026	16	800	0.3			
	3		5.61	0.039	32	1450	1.0			

DIMENSIONS

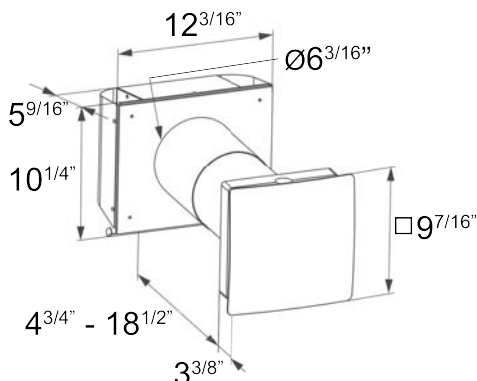

TwinFresh COMFO RA1-50-2

Single Room Total Recovery Ventilator

VENTILATION APPLICATION EXAMPLE BASED ON TwinFresh COMFO

One TwinFresh COMFO unit can serve rooms up to 343 SQ.FT

To arrange a ventilation system based on TwinFresh COMFO ventilators, install one unit in each room. For larger premises, install two ventilators. Units can operate independently or can be wired for master-slave operation.

Air flows from one room to another through door grilles, openings or halls and ensures required circulation in premises.

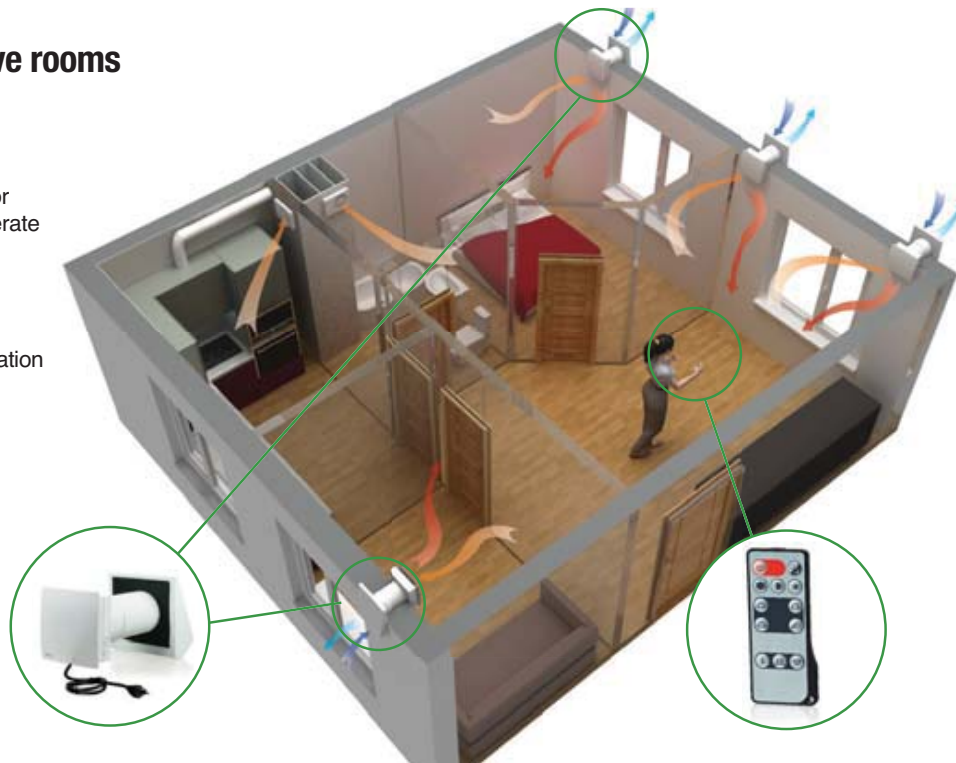

TwinFresh COMFO VS REGULAR ERV to ventilate a 4 bedroom house



VS.



TwinFresh COMFO		REGULAR ERV
No	Ductwork required	Yes
No	Dust collection inside a ductwork	Yes
No	Complicated wiring of the controls	Yes
No	Balancing is required	Yes
No	Professional installers are needed	Yes
No	Additional interior works to hide ducts	Yes
No	Separate room for installation	Yes
No	Antifreeze protection for core	Yes
< 24 W	Power consumption for a 4 bedroom house	> 100 W
≤ 90 %	Apparent Recovery Effectiveness	≤ 80 %
0.2-0.5	Sones/Sound level	3