



# Standard Top Down

## INSTALLATION MANUAL



P.O. Box 279  
Shakespeare, ON  
N0B 2P0

1-800-960-4002  
[www.faromor.com](http://www.faromor.com)

June 2013



# Table of Contents

Page 3	-	<b>Introduction</b>
	-	<b>General Considerations</b>
Page 4	-	<b>Framing Details</b>
Page 5	-	<b>Parts List</b>
Page 6-16	-	<b>Installation Instructions:</b>
		<i>Page 6: Curtain pulley</i>
		<i>Page 6: Wind rope and main cable screweye</i>
		<i>Page 7: End pulley bracket and winch</i>
		<i>Page 7: Pull up cable</i>
		<i>Page 8: Reverse pull-up cable</i>
		<i>Page 8: Top aluminum tube and lift tab</i>
		<i>Page 9: Curtain and bottom tube</i>
		<i>Page 9: Wind rope</i>
		<i>Page 10: Appendix A1 - End pockets - General</i>
		<i>Page 10: Appendix A2 - Inside end pocket</i>
		<i>Page 11: Appendix A3 - Outside end pocket</i>
		<i>Page 11: Appendix A4 - End pocket with track</i>
		<i>Page 12: Appendix A5 - End pocket completion</i>
		<i>Page 12: Appendix B1 - Manual drive unit</i>
		<i>Page 13: Appendix B2 - Linear Actuator</i>
		<i>Page 13: Appendix B3 - Manual override</i>
		<i>Page 14: Appendix C1 - Wind Protection Systems</i>
		<i>Page 14: Appendix C2 - Wind Pipe</i>
		<i>Page 15: Appendix C3 - Inside and outside wind pipes</i>
		<i>Page 15: Appendix C4 - Outside wind pipes only</i>
		<i>Page 16: Appendix C5 - Split double wind pipe</i>
		<i>Page 16: Appendix D1 - Wiring instructions</i>
Page 17	-	<b>Finishing Tips and Touches</b>
Page 17	-	<b>Warranty Policy</b>





# Introduction

**Standard Top Down (TD)** curtains are permanently fastened at the bottom of the opening and lowered (opened) from the top. In cold weather the initial air enters high on the side-wall to ensure ventilation with minimum draft.

Curtains are operated on a cable and pulley system and can be operated by manual hand winch or automated with linear actuator and thermostat.

## General Considerations

**\*\*Please read the following notes prior to installing the Standard Top Down Curtain:  
(For installation purposes, this manual shows “typical” installation with inside screen and outside wind ropes)**

- 1) Verify framing details are correct, as per page 4, to assure installation will work properly.
- 2) Read all instructions prior to beginning installation to familiarize yourself with parts and terminology.
- 3) Confirm what appendixes are required for your specific installation (manual vs automatic, wind ropes vs wind pipes, etc.)
- 4) Watch for “Faromor Tips” on installation pages for pointers that will assist with installation.
- 5) Please read final page “Finishing Tips and Touches” before completing installation.

# Framing Detail

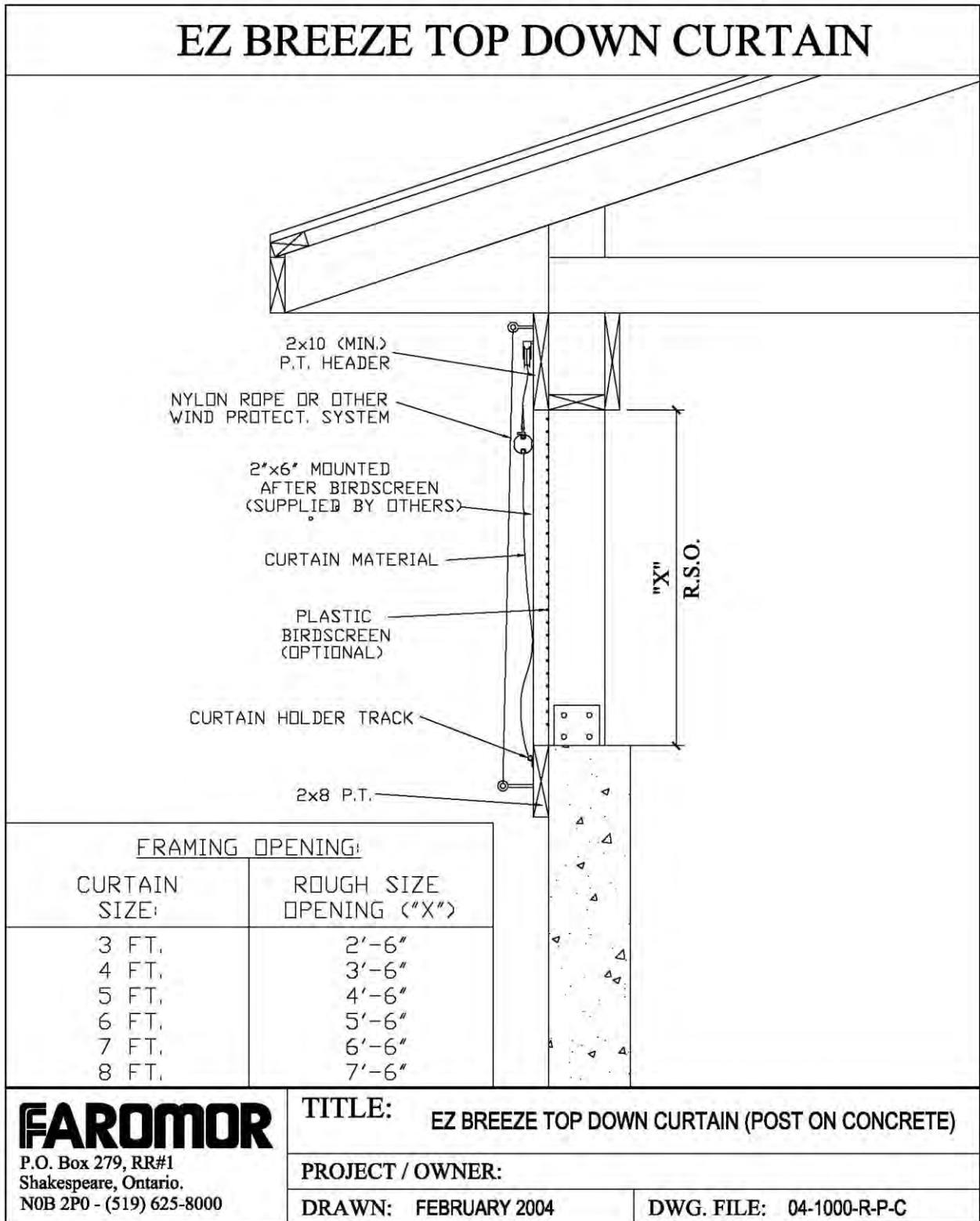

# Parts Listing

Item #	Part #	Description	Picture
1	04-241-03 to 04-241-12	End pocket with track	
2	04-241-03-01	End pocket "U" bracket	
3	04-241-03-02	End pocket bracket	
4	04-241-03-03	Tube holder bracket	
5	08-230-01-09	Aluminum tube	
6	04-143-03	3' curtain material - double rope	
7	ALCURTRACK	Aluminum track for gear box	
8	MTRACKSEAL	Gray rubber moulding	
9	BSCB5161 and NSHN516FF	5/16" x 1" s.s. carriage bolt and 5/16" s.s. hex nut	
10	BZHLB14X112 and SZWS14112TA	1/4" x 1-1/2" hex head lag and #14 x 1-1/2" pan soc head - zinc	
11	04-242-03 to 04-242-12	Outside Plain Pocket	
12	04-243-03 to 04-243-12	Inside end pocket (6' wide x curtain height + 1')	
13	WGRIPI0X1WW	#10 X 1 w/w woodgrip screws	
14	08-230-14-01	S.S. Curtain pulley	
15	MEB38412 MEB5154 MEL5156 MSE551010	Screweyes	
16	08-110-04	End pulley bracket	

Item #	Part #	Description	Picture
17	08-100-18 or 08-210-24-05	Stainless steel cable - 1/8" or 3/16"	
18	08-200-17-04 or 08-210-24-04	Cable clamp - 1/8" or 3/16"	
19	08-230-01-10	Aluminum lift bar for curtain	
20	08-230-01-08	Tube joiner for 2" tubing	
21	R316X34SF	Small head aluminum rivet	
22	08-230-01-02	#5 nylon wind rope	
23	08-230-25-02	Top "L" bracket	
24	08-230-25-06	"Foot" bracket	
25	ST12SCH40 GALV	1/2" galvanized wind pipe	
26	08-232-25-03	Bottom L Bracket for 2" Pipe Complete	
27	08-230-25-06	"Foot" bracket	
28	08-130-21	Aluminum curtain track	
29	08-231-25-04	Centre bracket for split wind pipes	
30			
31			
32			

# Curtain Pulley Installation

Use item #13, part #WGRIP10X1WW, page 5, for fastening pulley

Illustrated is the inside pocket. For inside pocket installation, see Appendix A2, page 10.

First pulley to be located 12" in from drive end.

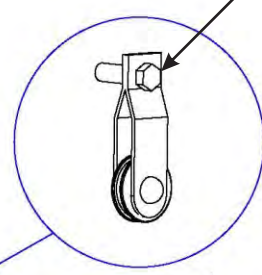
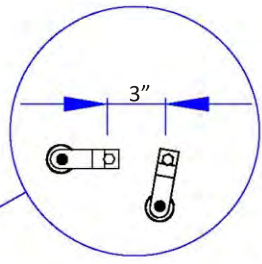

Pulley should be placed as high as possible on header approximately 1" from top

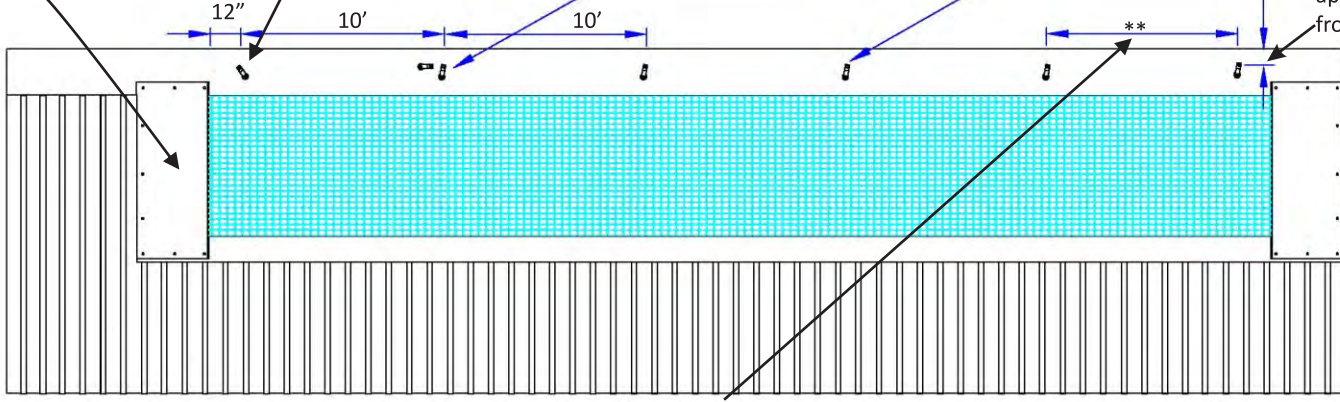

\*\* The last pulley should be 12" in from end pocket. The distance between the last two pulleys is variable. Please refer to page 8 for specific details.

# Wind Rope and Main Cable Screweye Installation

\*\*If a wind protection system other than wind ropes is being used, please refer to Appendix C1, pg. 14 for installation details.

Main cable guide screweyes are #MEB38412. They should be placed next to the pulley towards the non-drive end; and in line with top of pulley.

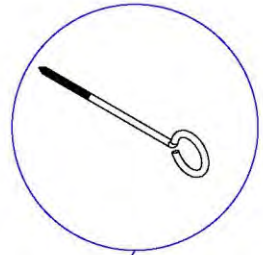

Top screweye to be mounted approximately 4" up from bottom of header.

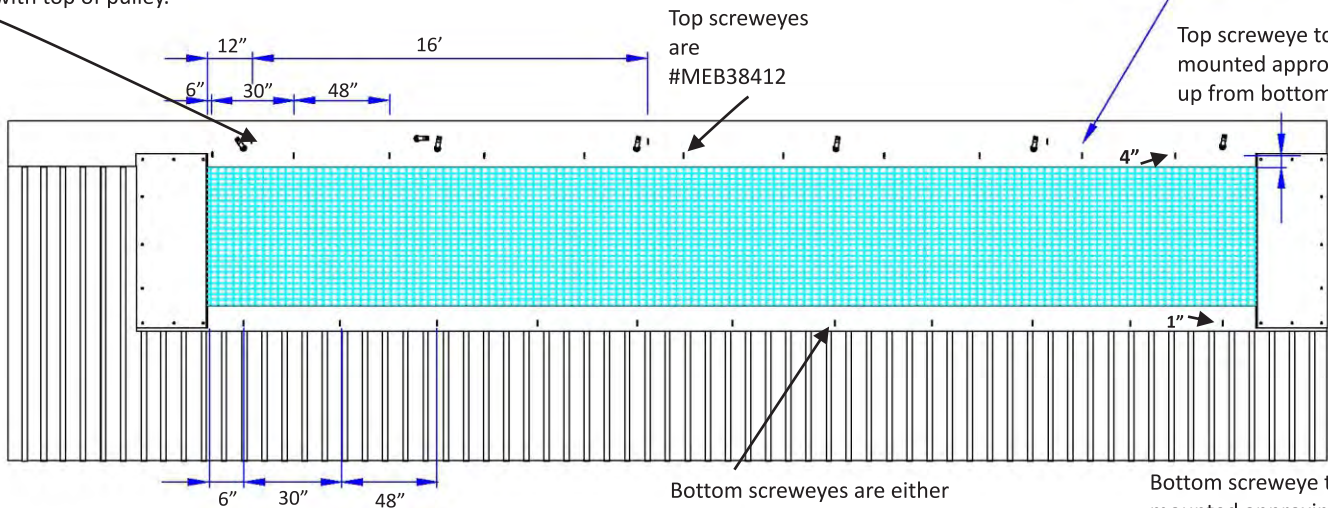

Bottom screweyes should line up with each pulley on top header. Another screweye is then placed halfway between each of the bottom screweyes.

Bottom screweyes are either #MEB5154 or #MEL5156. \*\*These should be marked on the packing list\*\*

Bottom screweye to be mounted approximately 1" up from bottom of 2x8.



# End Pulley Bracket and Winch Installation

Block pulley should be mounted in line with top of pull-up pulleys. It can be mounted at the outer edge of the end pocket.

**\*Note:** pulley must be mounted horizontally so it turns cable into the wall.

The outside block pulley and inside block pulley must line up for proper main cable operation.

**\*\*See next diagram.**

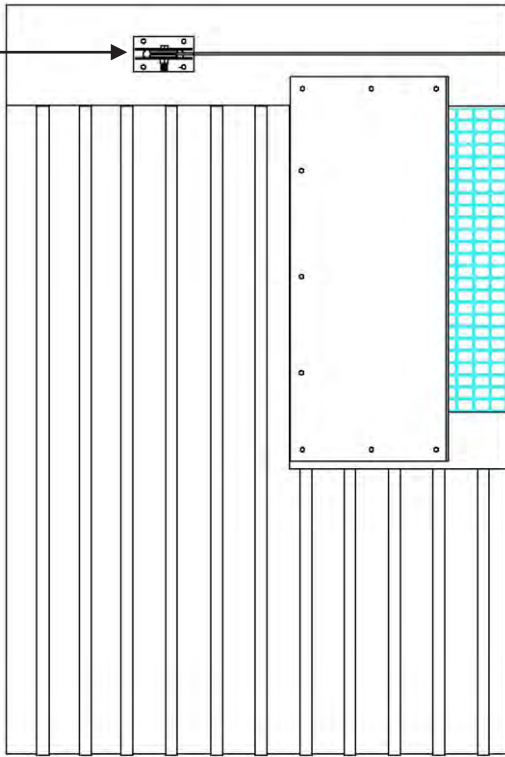

A hole must be drilled through header so the cable can pass through the building.

Interior block pulley should be mounted vertically to direct cable down towards winch.

Winch and bracket should be mounted at suitable height for operator with handle facing away from wall. The main cable should wrap several times around drum to hold in place.

Inside Outside

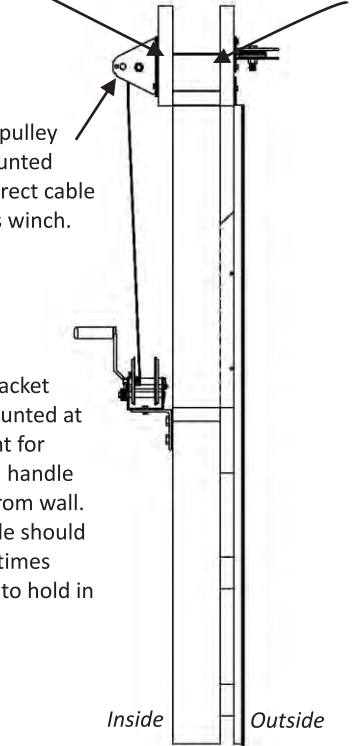

## Pull-up Cable Installation

**Step 3:** Thread pull-up cable over pull-up pulley on the side opposite the drive unit. Fasten cable to main cable using cable clamp provided approximately 6" beyond pulley.

**Step 1:** Connect main cable to winch or actuator. See appendix B1 & B2, pg. 12 & 13. Thread through inside and outside block pulleys and through all main cable screweyes.

**Step 4:** See pg. 8 for details on reverse pull cable

**Step 2:** Main cable should stop just past second last pulley or go approximately 12" beyond last pulley. See pg. 8 for details.

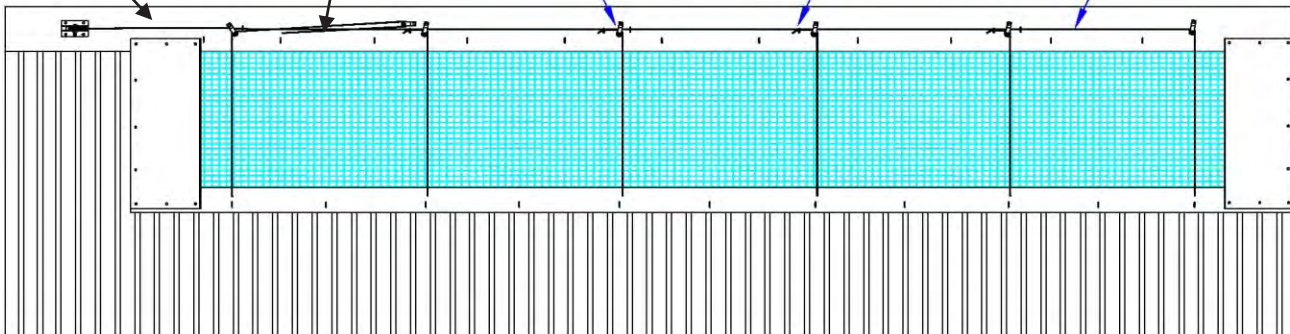
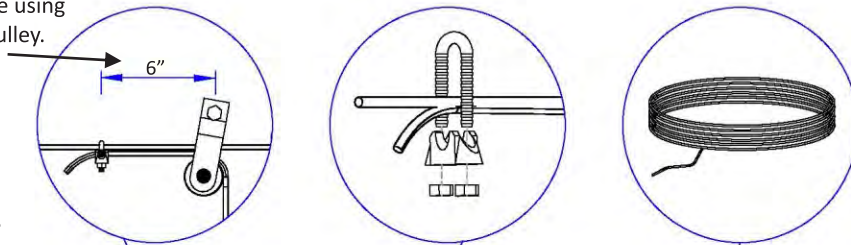

**Faromor Tip:** Tighten main cable so there is a small amount of tension on cable before pull-up cables are installed. To keep main cable tight during installation, it is recommended that you install a temporary screweye 12" beyond last pull-up pulley or second last pulley, depending on spacing. (See pg. 8) Fasten main cable to this screweye using cable clamp. **Note:** this screweye may need to be removed upon completion of cable installation.

# End Pull-up Cable Installation

## Reverse Pull-up Cable Drive-end

Reverse pull-up cable should be packed separately and is twice as long as standard pull-up cable.

**Step 1:** Thread cable through pulley - drive end side - and then thread back towards next pulley.

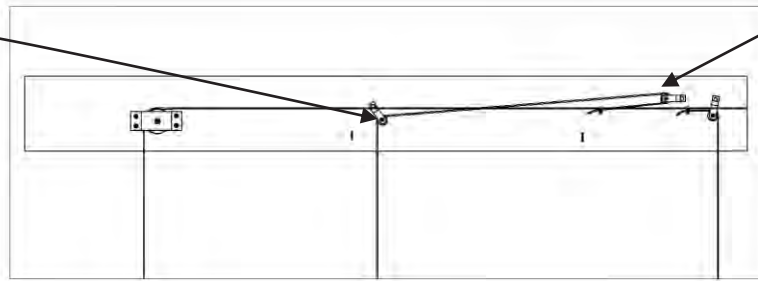

**Step 2:** Thread the cable around the top of pulley, turn cable back towards drive end and connect to main cable with clamp provided leaving 6" space as per previous cables.

## Non-drive End Pull-up Cable

If distance between last two pulleys is 8' or more, use Option A  
If distance between last two pulleys is less than 8', use Option B

*Temporary screweye - do not remove - it will be used as a cable guide*

Option A

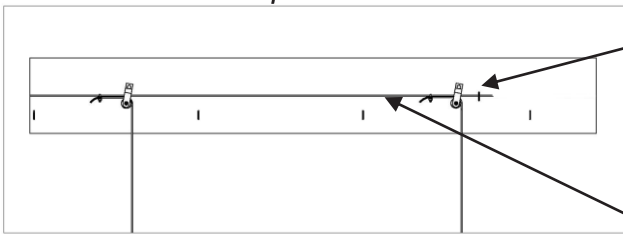

*Temporary screweye - remove after cable installation*

Option B

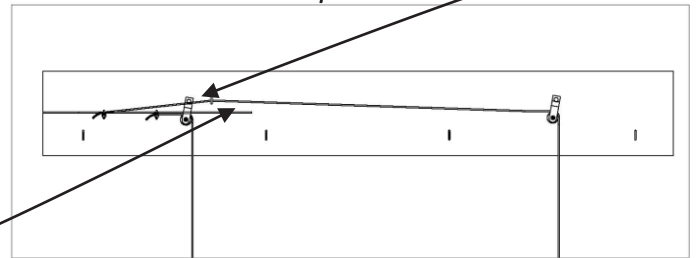

*Main cable*

If distance between last pulley and second last pulley is 8', run main cable 12" past last pulley. Use 1/8" pull-up cable and attach to main cable as per other pull-ups.

If distance between last two pulleys is less than 8', run main cable 12" past second last pulley. Use 1/8" cable for last pull-up, thread over pulley, through temporary screweye, and attach to main cable to the left of previous cable clamp.

# Top Aluminum Tube and Lift Tab Installation

**Step 1:** Take one length of 2" aluminum tube, slide in accompanying joiner as specified below, fasten tube to joiner, and slide next piece of aluminum tube over joiner. Butt two pieces of aluminum tube together and fasten second piece to joiner. (joiner should be fully enclosed)

**Step 3:** Slide aluminum lift tabs into tube keeping bottom of "L" shape to outside. Line up aluminum tabs with drop cables. Attach cable to tabs, going from back to front, and fasten cable to itself with cable clamp supplied. **\*\*Note:** cable clamp nuts should be facing away from the building.

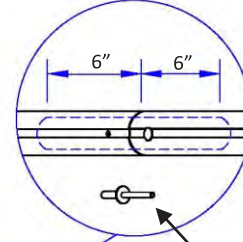
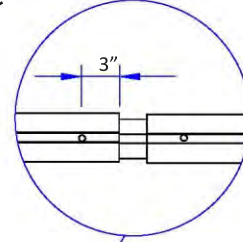
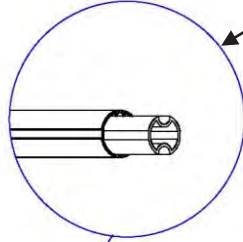
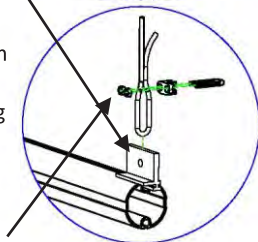

**Step 2:** Drill appropriate sized hole through tube and joiner; fasten tube and joiner together with pop rivets supplied. (rivet head

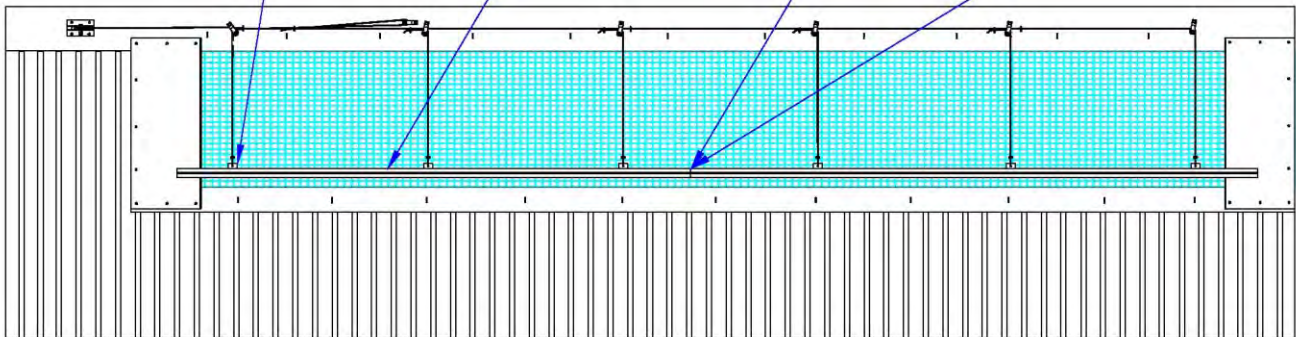

**Faromor Tip:** To ensure drop cable lengths are even, lay entire length of aluminum pipe onto bottom screweyes. Attach cable to lift tabs and tighten securely. (hold aluminum pipe firmly onto screweyes to avoid lifting of pipe)

# Curtain and Bottom Track Installation

**Step 1:** Sewn into the top and bottom of curtain material is a nylon rope. With top tube raised to convenient height begin sliding rope/curtain material into aluminum tube. Slide curtain to far end of tube so curtain is fully unrolled. If curtain material is too long it can be cut to size.

*\*\*See Faromor tip.*

**Step 2:** Raise curtain to top of opening so it is in the closed position. Take one length of aluminum track, slide onto bottom rope on curtain material with flat part pointing down and against the wall. Slide all the way to far end of curtain. Take second piece of aluminum track, slide onto bottom of curtain and butt up against first piece. Continue in this fashion until all necessary track is installed.

**Step 3:** Starting from one end, hold aluminum track and pull downwards until curtain material is tight. Put track onto bottom board and fasten with screws provided. Continue fastening track at 12" intervals.

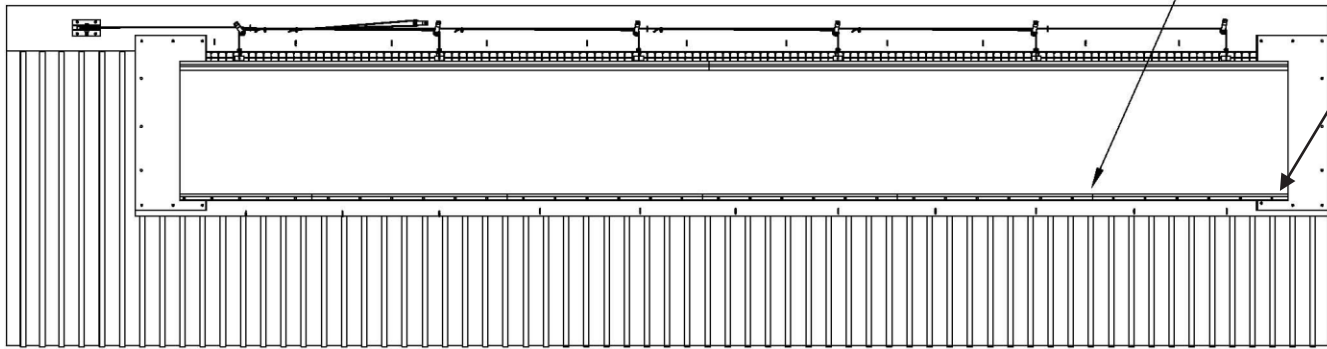
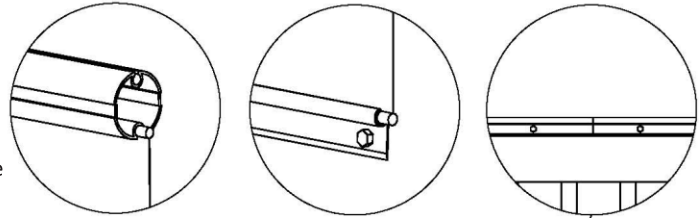

Note: Curtain material and track should be installed at least halfway onto inside end pocket.

**Faromor Tip:** 1) Before sliding rope/curtain into top tube, temporarily fasten top tube to wall at one end to prevent pipe from moving while pulling curtain. **\*\*Note:** Remove temporary fastener from tube when complete.

2) To prevent curtain from moving while installing bottom track, fasten rope/curtain to top aluminum tube by screwing self-drilling screw through rope into aluminum at one end.

## Wind Rope Installation

At this point, the curtain must be raised to the closed position. This can be done by cranking manual winch or override winch with main cable attached. See drive unit installation Appendix B1 or B2, pg. 12 or 13. The top aluminum tube should come completely onto top header but not touching top screweyes.

To install wind ropes, attach one end of rope to first top screweye by tying a knot. Thread rope down through first bottom screweye, then back up to next top screweye. Continue in this zig-zag fashion to end of section.

**\*\*Note: It is recommended that the rope be installed in approximately 50' sections. Tie off rope at a bottom screweye and start next 50' length on same screweye. (As the rope will stretch over time, this will allow you to more easily tighten or repair when necessary)**

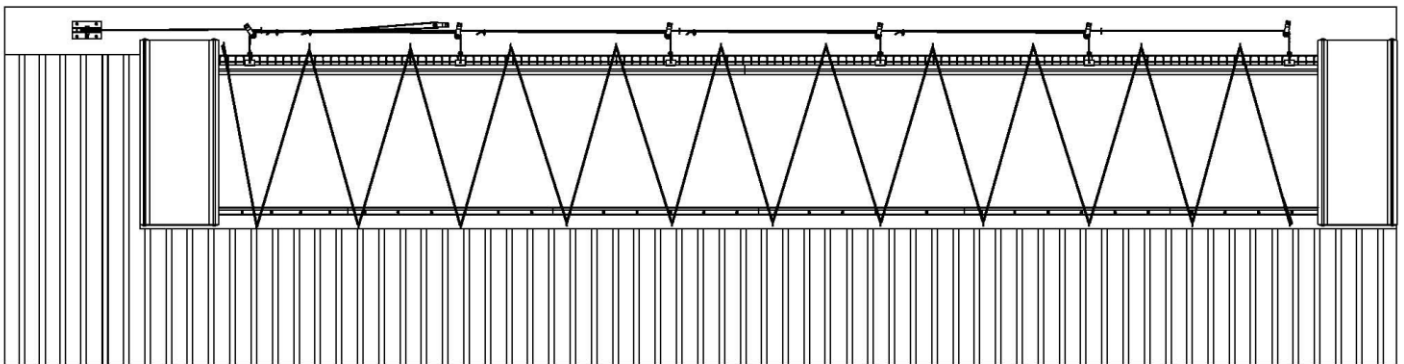

To complete curtain installation, you can now install the outside end pockets (See Appendix A3, pg. 11)

# Appendix A1 - End Pocket Installation

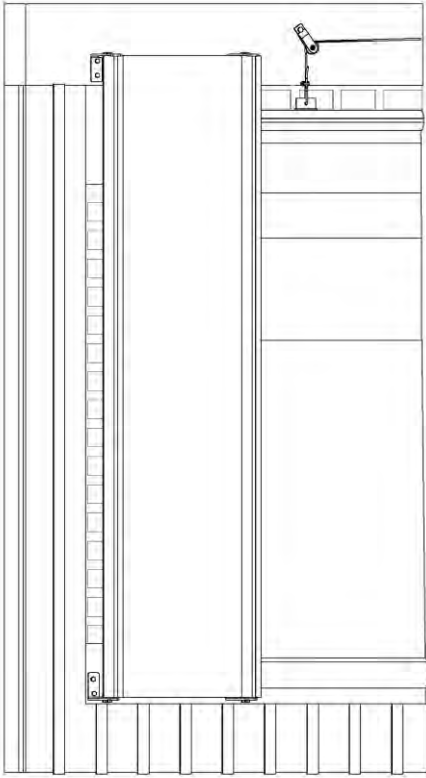

## GENERAL

Inside end flap must be installed first.

The height of a pocket is one foot higher than curtain height.

Outside end pockets are determined by curtain styles. There will either be two plain pockets (as shown here); or one plain and one pocket with tracks.

For plain outside end pocket assembly, see pg. 11.

For pockets with tracks, (used with split curtain installations), see Appendix A4, pg. 11.

**\*\*Please note: For Roll-A-Way curtains, and Standard Top Down curtains (with Summer Roll-Up or on a split curtain system), you must use an end pocket with track to match top and bottom.**

---

# Appendix A2 - Inside Pockets

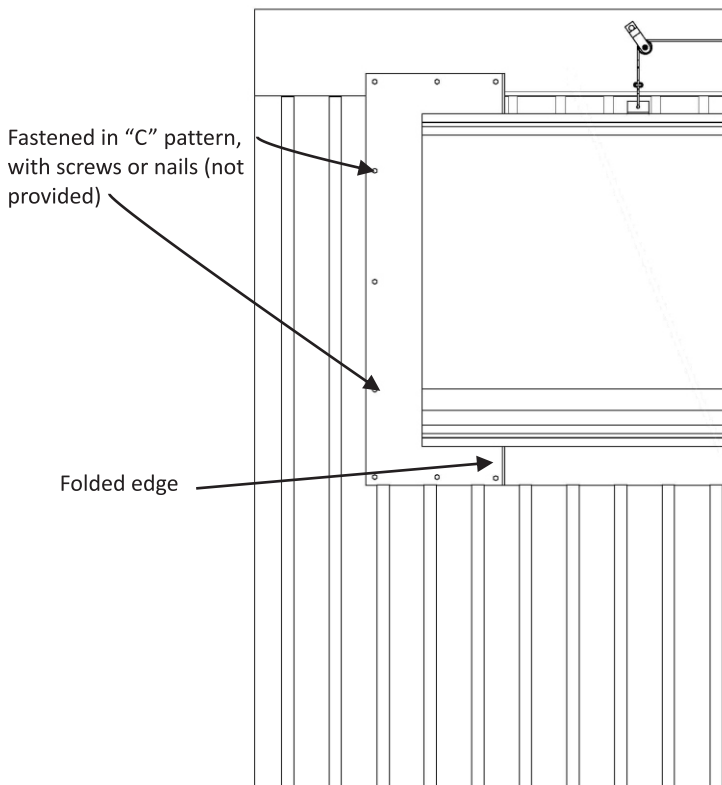

Inside end pockets are the same for any style of curtain.

The inside flap is 6' wide material that is folded in half to make a 3' wide inside pocket. The height of the pocket will be one foot longer than the height of your curtain; e.g. 4' high curtain requires 5' high end pocket.

The inside flap should be mounted at both ends of the curtain opening. The folded edge is to the interior of the opening. (See diagram)

You must fasten the material to the wall along the top, the outer edge, and the bottom in a "C" pattern. (see diagram)



# Appendix A3 - Outside Plain Pocket

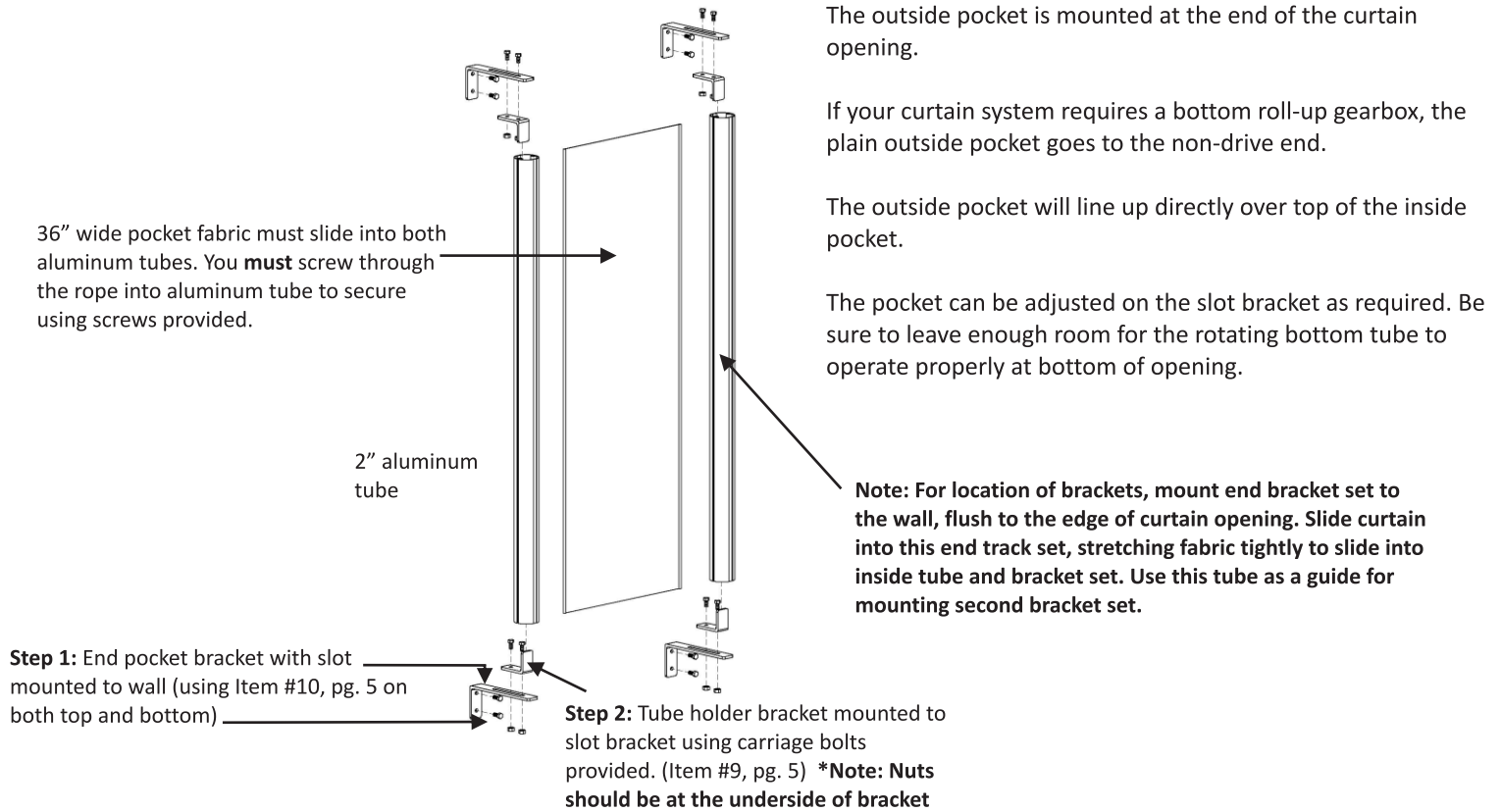

# Appendix A4 - End Pocket with Track

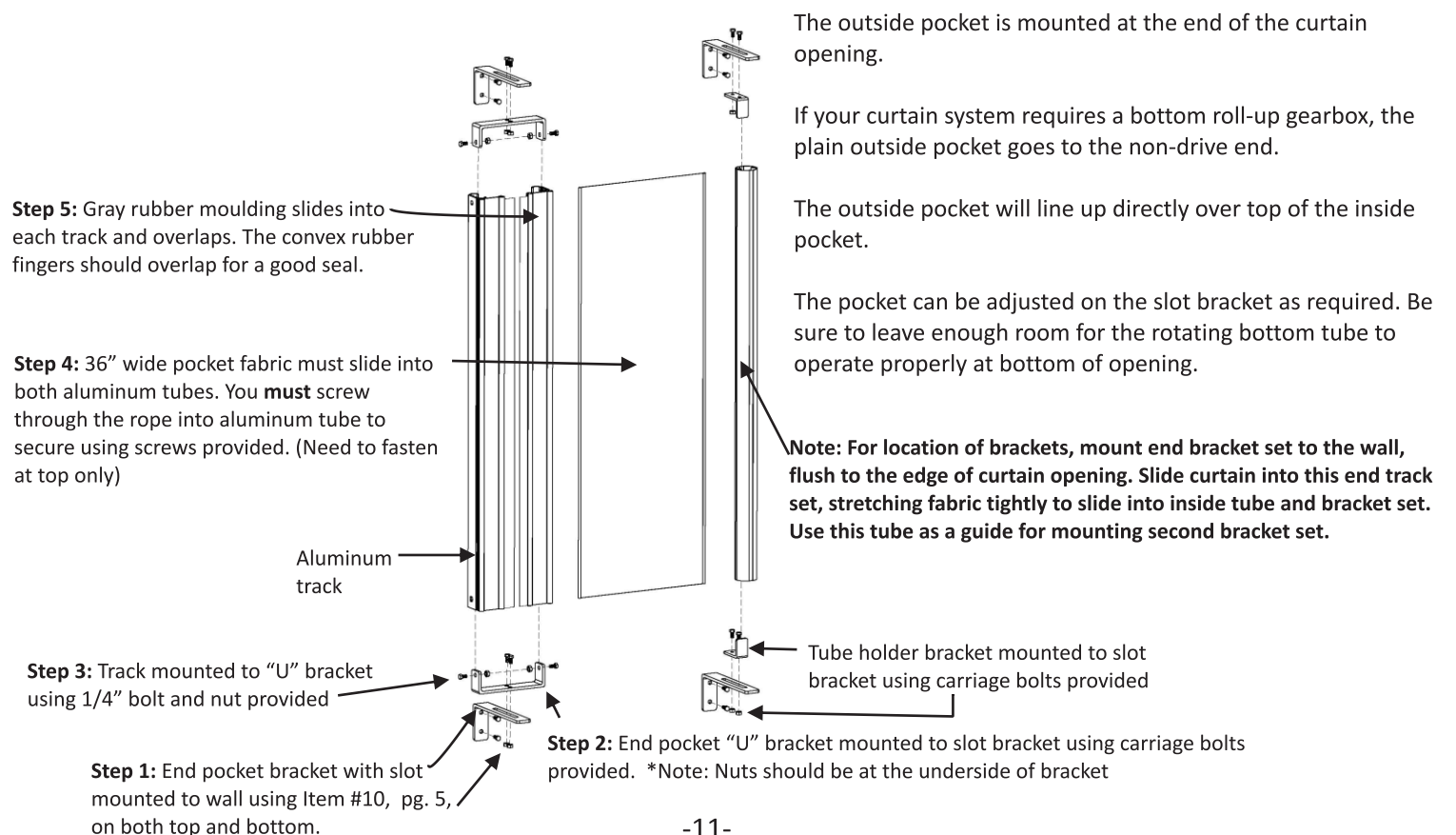

# Appendix A5 - End pocket Completion

To complete the end pockets, we must now close in the very end of the sections. On either style of end pocket (with or without track) you will have a groove in the aluminum at the outermost edge to allow curtain material to slide in. Use one foot wide curtain material with rope and slide into track or tube.

Make sure curtain material reaches top to bottom, pull material onto framed opening and fasten to wall using plastic nailer strip and woodgrips provided. Trim off excess curtain material as required.

**\*\*Note: For Roll-A-Way curtains only: On drive unit end, curtain material must finish approximately 3" above protruding aluminum tube.**

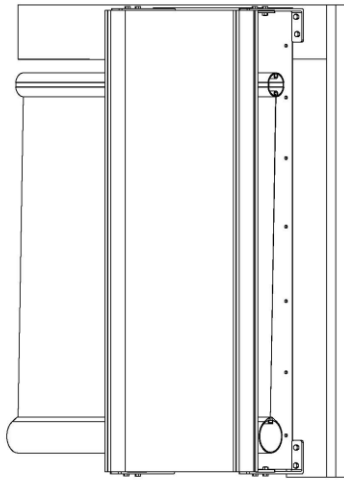

**Step 1:** End pocket before installation of fabric closure strip.

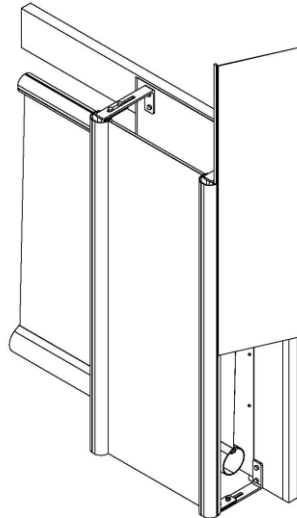

**Step 2:** Install fabric end closure strip - slide into aluminum tube from top or bottom.

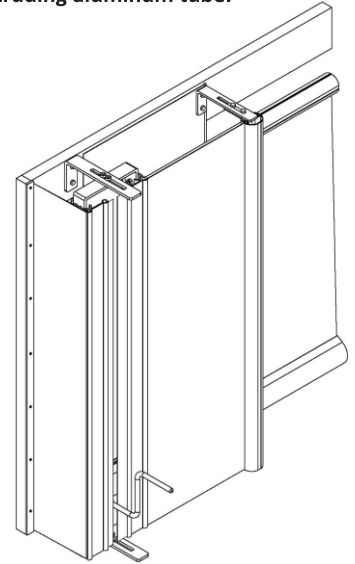

**Step 3:** Install plastic or wood nailer strip. (Can be mounted as shown or wrapped to outside to hide strip)

# Appendix B1 - Manual Drive Unit Installation

Manual drive units are interchangeable from right-hand to left-hand.

*\*\*Illustration is for a right hand drive unit*

Gear box drive unit is mounted into the outermost track on the end pocket.

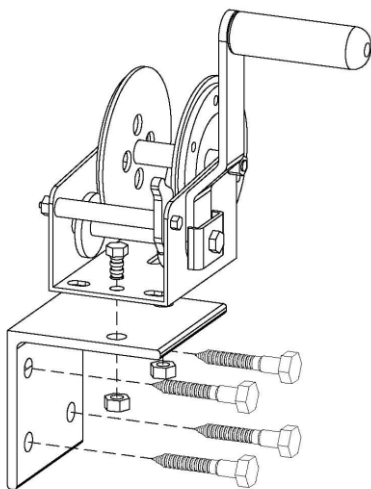

To mount winch on wall, find suitable location directly beneath end pulley bracket so cable stays straight. Mount winch bracket to wall with lags provided and mount winch to bracket with nuts and bolts provided. Install handle to winch to begin operation.

Connect main cable to winch by threading cable through winch drum and gathering slack cable on drum.

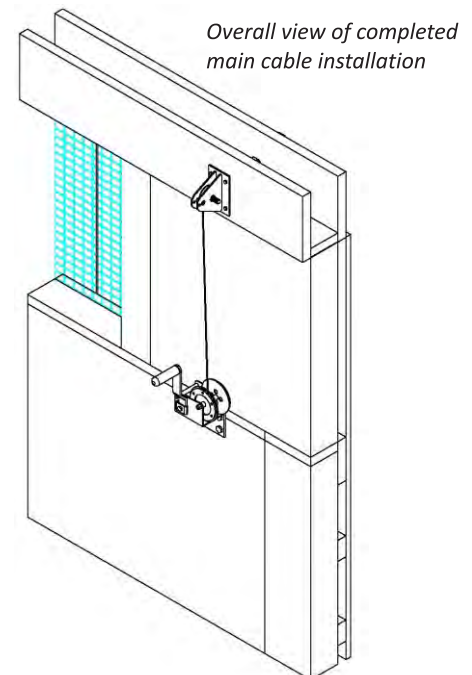
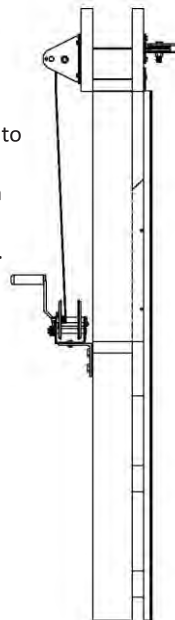

*Overall view of completed main cable installation*

# Appendix B2 - Linear Actuator Installation

Linear actuator can be installed either horizontally or vertically on the inside of the building. The actuator must be situated so that the main cable comes from the inside pulley and can attach to the nose piece.

Each actuator must be located a minimum of twice the stroke length plus one foot away from end pulley. i.e., 3' actuator should be 7' away from end pulley.

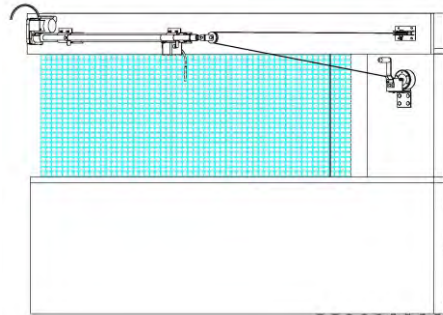
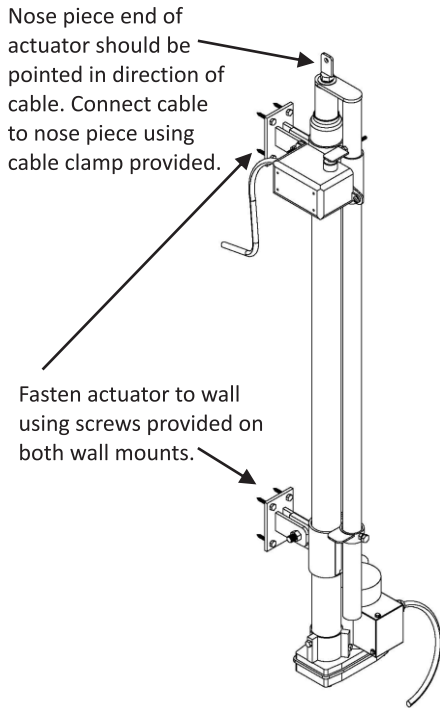

Depicts typical actuator installation with override kit. See Appendix B3, pg. 13 for override options.

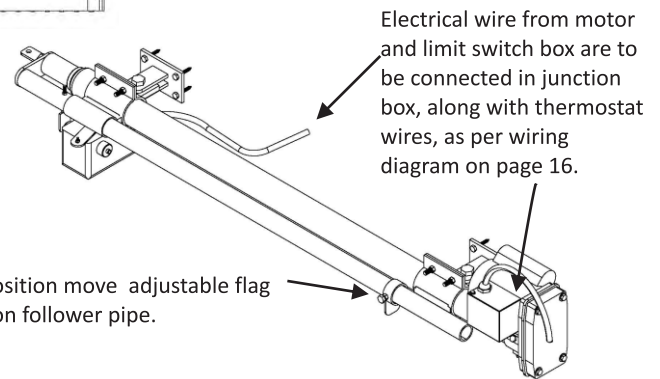

# Appendix B3: Manual Override Installation

## Manual Override for Double Pull Actuator

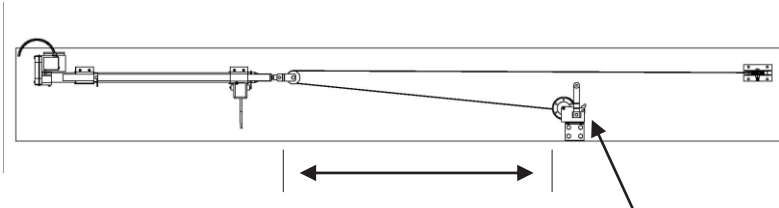

Distance from pulley to manual winch must be greater than actuator stroke length plus one foot.

Manual winch placement is variable. (see pg. 12)

## Manual Override for Single Pull Actuator

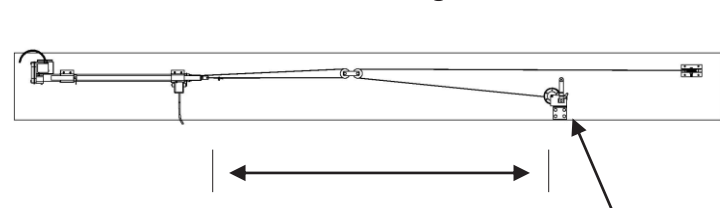

Distance from pulley to manual winch must be greater than actuator stroke length plus one foot.

Manual winch placement is variable. (see pg. 12)

With actuator in closed position (where limit switch is touching flag), thread main cable around end pulley through pulley on end of actuator and connect to manual winch. Crank manual winch until outside curtain comes to fully closed position. The actuator may now be used in automatic mode.

**Step 1:** Attach override cable to nose piece of actuator using cable clamp, thread around one wheel of double floating pulley, bring cable back to actuator, and attach to foot mount bracket using cable clamp.

**\*\*Note:** Be sure not to leave cable too long or too short. Adjust for proper length at end of installation, i.e. twice length of stroke plus one foot.

**Step 2:** Thread main cable around inside end pulley through second wheel on double floating pulley and attach to manual winch. With actuator in closed position, crank winch until curtain is in closed position. You may now operate actuator in automatic mode.

# Appendix C1: Wind Protection Systems

## Inside Wind Protection System Options

**\*\*If installing birdscreen, it should be done first.\*\***

However if using inside wind rope system it can be installed at the same time as outside wind rope on pg. 9.

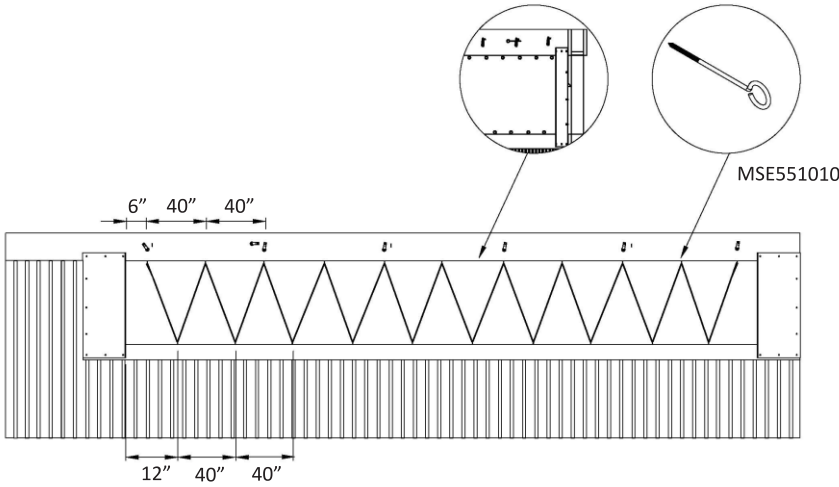

Birdscreen option

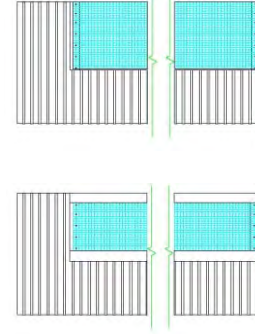

Birdscreen should be installed prior to top header and bottom board and should be installed from one end of opening to the other. To install birdscreen, fasten at one end of opening using galvanized roof nail (not supplied). Stretch roll to next post and fasten with same fasteners and continue until other end of opening. **\*\*Note: Keep birdscreen as tight as possible to avoid wrinkles.**

If inside wind rope is being installed use small screweye for both top and bottom. Spacing of inside screweyes should be opposite those on page 10. The inside top screweye should line up underneath each pulley and spaced as per above. Screweyes are to be mounted on underside of header and on top of bottom board.

**\*\*Note: It is recommended that the rope be installed in approximately 50' sections. Tie off rope at a bottom screweye and start next 50' length on same screweye. (This will allow you to more easily tighten and repair wind rope if necessary)**

Once birdscreen is covering the full opening, you can now install top and bottom boards which will sandwich the birdscreen and help hold it in place.

# Appendix C2: Wind Pipe Installation

If curtain system is to have both inside and outside wind pipes, install inside wind pipe after curtain pulley installation on page 6. If system is to have outside wind pipes only, they should be installed as the last step of the overall installation.

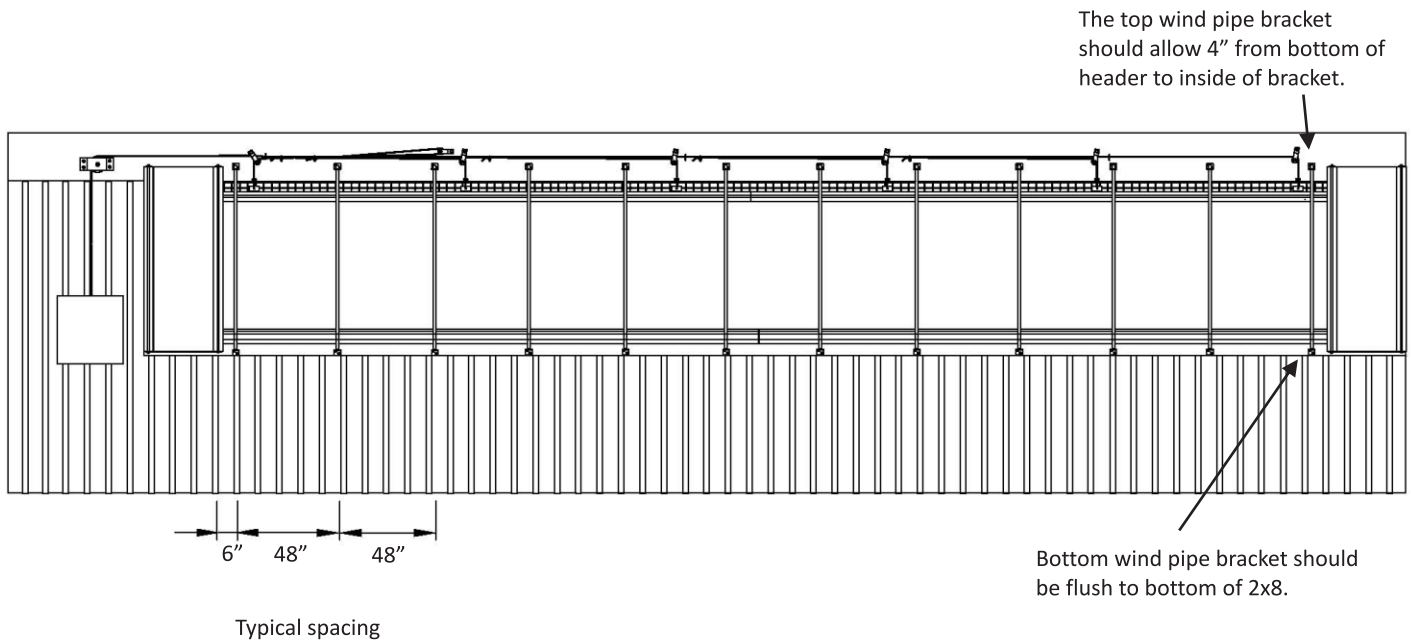

The top wind pipe bracket should allow 4" from bottom of header to inside of bracket.

Bottom wind pipe bracket should be flush to bottom of 2x8.

Typical spacing

# Appendix C3: Wind Pipe Installation

This illustrates a curtain system with wind pipes inside and outside.

**Step 6:** Mount top "L" bracket to header with screws provided (leaving 4" from bottom of header to bracket).

**Step 5:** Move "foot" bracket to underside of header, and fasten with screws provided. \*Note: you will have to measure and cut inside wind pipes to ensure proper fit.

**Step 4:** Insert top "foot" bracket into top of wind pipe.

**Step 7:** Slide outside wind pipe through hole in "L" bracket and place bottom of pipe over pin of bottom "L" bracket.

\*Note: pipes may need to be cut to proper length.

**Step 3:** Place inside wind pipe over pin of foot bracket.

**Step 2:** Fasten foot bracket to top of bottom board or concrete using fasteners provided.

**Step 1:** Bottom "L" bracket with pin should be mounted on bottom board with pin facing upwards. Allow enough space for aluminum tube (minimum 3") Spacing is noted in Appendix C2, page 14.

**\*Note: Outside wind pipe should not be installed until all curtains are hung.**

---

# Appendix C4: Wind Pipe Installation

This illustrates a curtain system with wind pipes on outside only.

**Step 3:** Slide outside wind pipe through hole in top bracket and place bottom of wind pipe over pin on bottom bracket. \*Note: wind pipe may need to be cut to ensure proper fit.

**Step 2:** Mount top "L" bracket to header with screws provided (leaving 4" from bottom of header to bracket). \*Note: Hole in "L" bracket should be centred over pin on bottom bracket.

**Step 1:** Fasten non-pin end of bottom bracket to wall (with pin facing up), using fasteners provided. Keep as low as possible on bottom board. \*Note: For spacing details, see Appendix C - page 14.

**\*Note: Outside wind pipe should not be installed until all curtains are hung.**



# Appendix C5: Wind Pipe Installation

This illustrates a split curtain system with inside and outside wind pipes.

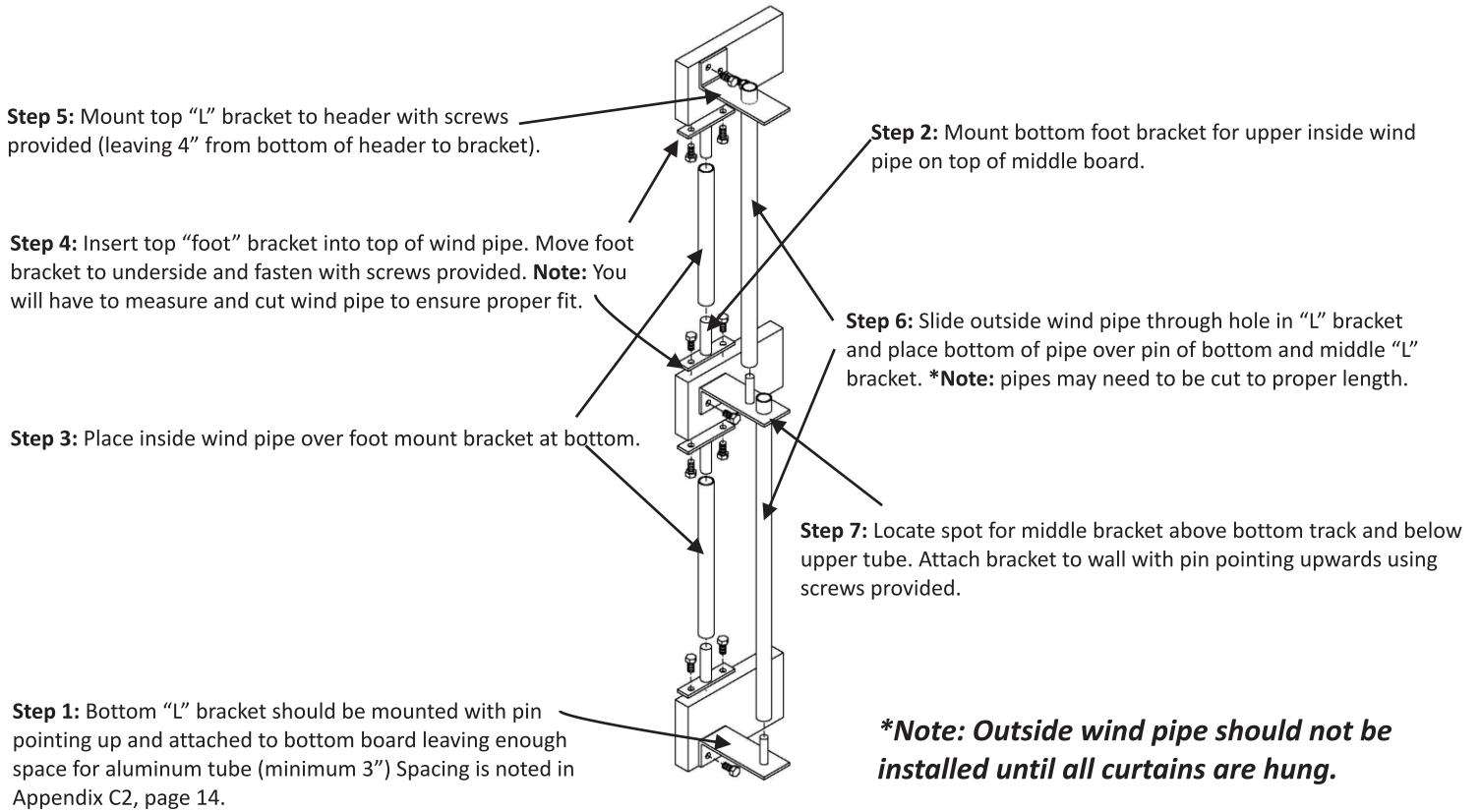

# Appendix D1: Limit Switch System

## PARTS FOR LIMIT SWITCH ASSEMBLY:

DESCRIPTION	QTY:
BOX WITH BUSHING AND NUT	1
LID WITH SCREWS	1
SWITCH WITH CORRECT O-RING	2
PIECE OF 5-WIRE	1
8-32 BOLT (1/2") c/w NUT	2

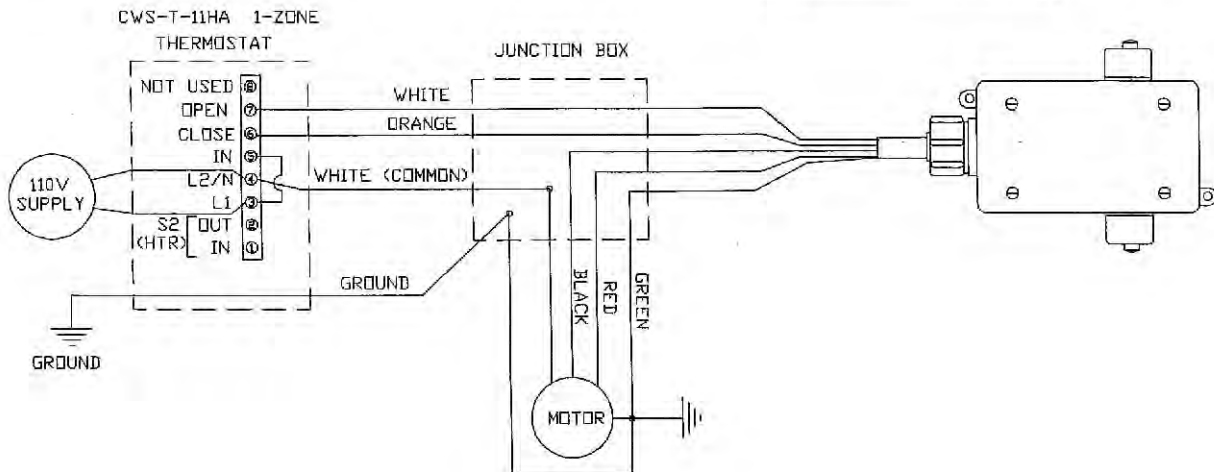
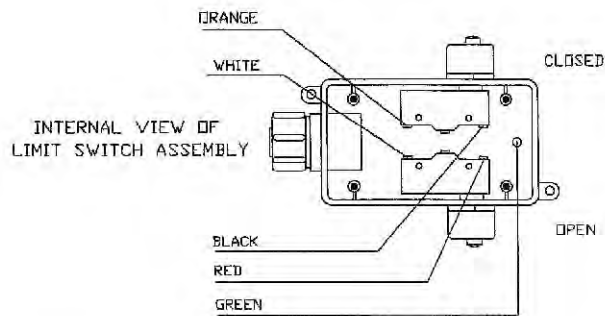

## Finishing Tips and Touches

- 1) Double check all pull-up pulleys and flush mount pulleys to ensure smooth operation. Check all cable movements and ensure that no cables are getting caught or stuck which will result in curtain not operating properly.
- 2) Use a small piece of electrical tape to tape off all loose ends of pull-up and main cables. This will help to prevent fraying of cables, which can result in curtain being damaged.
- 3) Ensure end pockets are proper distance away from wall after installation is complete. They should allow curtain to roll and have some movement in and out from wall, but not allow excessive movement that might be caused by strong winds permitting excessive air leakage.
- 4) If using linear actuator, ensure limit switches are set properly and securely before using curtain in automatic mode.

### **WARRANTY POLICY**

Faromor Ltd. Warranty Policy covers all parts manufactured and supplied by Faromor. Warranty starts from date of initial installation of product and lasts one (1) year.

Faromor will also give full warranty on any installation labour we provide for a period of up to one (1) year from date of installation.

All digital thermostats have a two (2) year full warranty.

## CURTAIN SYSTEMS SAFETY PRECAUTIONS

**NOTE: ALL INSTALLATION OF ELECTRICAL CONTROLS SHOULD BE DONE BY A QUALIFIED ELECTRICIAN.**

### General Operation

- Curtains should only be operated when the owner or other responsible persons are in the facility.
- Unauthorized persons or small children should not be near or have access to the outside or inside automatic/manual drive units as they may result in injury. Do not attempt to stop any automatic drive unit by hand while it is in operation.
- Do not attempt to adjust cables or pulleys while system is in operation.
- When making adjustments to automatic drive units, ensure that the override switch is in the “off” position so that the curtain cannot start while any work is being completed.

### Protective Covering

- Ensure that all drive units (manual or automatic) have the covers installed where applicable.
- Electrical motors mounted on outside of building should be covered to prevent damage.

## CURTAIN SYSTEMS MAINTENANCE

### RAW/BRU/STD/STDS

- All cables (main and pull-ups) should be checked on a monthly basis to ensure proper operation. Over time, some cables may stretch causing uneven pull up of curtain system. Where necessary, loosen cable clamp, pull cable tight and re-fasten clamp when curtain is level.
- Ensure all cable clamps are tightly secured so it does not result in drop cables coming loose.
- Ensure curtains remain pulled tight from one end to the other. If curtain seems to be bunching or creasing, curtain may need to be tightened.
- Check all pulleys for excess wear on wheels that may cause cable to get caught.
- Periodically check over aluminum tubes to ensure they are connected tightly.
- Check end pockets to ensure all nuts and bolts are tightly secured.
- Tighten windropes as necessary to make sure there is no slack.
- For bottom roll-up systems, ensure aluminum track is clear of any debris and that gearbox wheels are turning smoothly.

### PRC

- Ensure all mounting brackets are secured tightly to wall and to end of aluminum tube.
- Periodically check that center support rollers are rolling properly and not seized.
- If applicable, ensure valance does not get caught in roller tube.
- Check for wear on sidewall seals periodically if heavy cow traffic is an issue.

**NOTE: FOR ANY SERVICE ON THERMOSTATS OR AUTOMATIC DRIVE UNITS, PLEASE CONTACT A FAROMOR SERVICE REPRESENTATIVE FOR ASSISTANCE. FOR ADJUSTMENT OF LIMIT SWITCHES SEE INSTALLATION MANUALS – ELECTRICAL SECTION.**



**General Cleaning:**

- Use mild soap or detergents for cleaning any of our Faromor products – do not use solvents or aggressive cleaning agents.
- High pressure washers can be used on all products but maintain a minimum distance from product of approximately 1m so as not to put too much pressure on the material – especially fabric curtains.
- Ensure rolling curtains are in the fully closed position when washing so that excess water does not get caught in the rolls of the fabric – allow the water to run completely off the curtains.
- Avoid direct pressure on any curtain area that has an existing hole or ClearVu panel that has an existing crack – the added water pressure may cause more damage at those locations.
- **FOR DRIVE UNITS** – it is recommended to do a simple hand cleaning of the units with warm water and avoid excess water around the motor, wiring or vent plugs so no water will enter the gears or damage the wiring – this will cause premature failure.

**NOTE: DO NOT USE HIGH PRESSURE WASHERS OR WATER OF ANY KIND TO CLEAN DRIVE UNITS OR THERMOSTATS – THIS WILL DAMAGE THE UNITS.**