



MCU & MCUA - LOW STAND INDUSTRIAL MANCOOLERS

Designed to provide cooling effects to large, open areas.

PERFORMANCE SPECIFICATIONS

FEATURES

- Drums and motor supports are constructed of heavy gauge steel.
- TEFC continuous duty, ball bearing motors are standard.
- All models are direct drive and available with steel blades or cast aluminum blades.
- Heavy duty, concentric circle, OSHA wire guards are standard on all sizes.
- Consult factory for availability of explosion-proof motors.

Non-stock, made-to-order products are non-returnable and cannot be cancelled.

DIMENSIONS

FAN SIZE	A	B	C	D	E (Tube I.D.)	F
18"	30 1/2"	30 1/4"	58 2/3"	21"	18 3/8"	17 4/7"
24"	36 1/2"	30 1/4"	61 2/3"	21"	24 3/8"	23 4/7"
30"	42 1/2"	30 1/4"	64 2/3"	21"	30 3/8"	29 4/7"
36"	--	--	67 2/3"	27"	36 3/8"	--
42"	--	--	70 2/3"	32"	42 3/8"	--
48"	--	--	73 2/3"	32"	48 3/8"	--

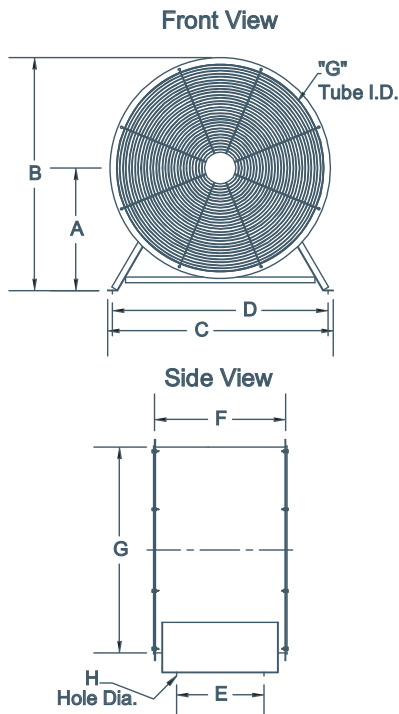

MCU STEEL FAN BLADE						
FAN SIZE	MODEL #		RPM	H.P.	MCS CFM	dBA @ 5 Ft
	SINGLE PHASE	THREE PHASE				
	12"	MCU12T10033C	MCU12T30033C*	1140	1/3	940
MCU12T10033B		MCU12T30033B*	1750	1/3	1422	65
18"	MCU18T10025C	MCU18T30025C*	1140	1/3	2654	64
	MCU18T10050B	MCU18T30050B*	1750	1/2	4016	74
24"	MCU24T10075C	MCU24T30075C*	1140	3/4	6549	73
	MCU24T10100B	MCU24T30100B*	1750	1	6761	81
	MCU24T10300B	MCU24T30300B*	1750	3	9909	84
30"	--	MCU30T30150C*	1140	1.5	11600	79
	MCU30T10500B	MCU30T30500B*	1750	5	17552	90
36"	--	MCU36T30200D*	860	2	16364	80
	--	MCU36T30500C*	1140	5	21692	88
42"	--	MCU42T30500D*	860	5	24499	85
	--	MCU42T30500C*	1140	5	23209	88
48"	--	MCU48T30750D*	860	7.5	35654	89
	--	MCU48T30750C*	1140	7.5	32563	92

MCUA CAST ALUMINUM BLADE						
FAN SIZE	MODEL #		RPM	H.P.	MCSA CFM	dBA @ 5 Ft
	SINGLE PHASE	THREE PHASE				
	12"	MCUA12T10033C	MCUA12T30033C*	1140	1/3	1450
MCUA18T10033C		MCUA18T30033C*	1140	1/3	2990	60
18"	MCUA18T10075B	MCUA18T30075B*	1750	3/4	4590	71
	MCUA24T10100C	MCUA24T30100C*	1140	1	6520	69
	MCUA24T10150B	MCUA24T30150B*	1750	1.5	7660	72
24"	MCUA24T10300B	MCUA24T30300B*	1750	3	11500	79
	MCUA30T10100C	MCUA30T30100C*	1140	1	8680	69
	--	MCUA30T30150C*	1140	1.5	11800	73
30"	MCUA30T10300B	MCUA30T30300B*	1750	3	13300	78
	MCUA30T10500B	MCUA30T30500B*	1750	5	18200	82
	--	MCUA36T30200C*	1140	2	14000	76
36"	--	MCUA36T30300C*	1140	3	19400	77
	MCUA36T10500B	MCUA36T30500B*	1750	5	16200	78
	MCUA36T10750B	MCUA36T30750B*	1750	7.5	21500	85
42"	--	MCUA42T30200D*	860	2	19200	73
	--	MCUA42T30300D*	860	3	23210	75
	--	MCUA42T30500C*	1140	5	25500	79
	--	MCUA42T30750C*	1140	7.5	30690	81
	--	MCUA42T31000B*	1750	10	26700	86
48"	--	MCUA48T30500D*	860	5	29820	78
	--	MCUA48T30750D*	860	7.5	35700	80
	--	MCUA48T31000C*	1140	10	39500	84
	--	MCUA48T31500C*	1140	15	47300	86

For three phase motors, substitute "*" with "M" for 208-230/460 volt or "P" for 575 volt
dBA ratings shown are measured at 0" static pressure and should be used as a guideline only.

OPTIONS

- Junction box installed on the outside of the fan body.