



MA SERIES

Axial Fans

Axial extract MA fans with automatic shutters are designed for through the wall or wall mount application. Air performance tested as per AMCA standards.

Certified by ETL and conforms to UL & ULC electrical safety standards.

FEATURES

- Sizes available from 4", 5", 6"
- Quiet and powerful
- Automatic shutters
- Vibration free operation
- Easy installation
- Corrosion resistant
- UV resistant, UL94 certified plastic
- ETL listed

APPLICATIONS

- Bathroom exhaust
- Living area

MOTOR

Sleeve bearing motor ensures quiet operation and designed for operation up to 20,000 hours. Suitable for air stream temperature from 34 °F to 113 °F.



FAN OFF - LOUVER SHUTTERS CLOSED



FAN ON - LOUVER SHUTTERS OPEN



MOUNTING EXAMPLE

SPECIFICATIONS

MODEL	RPM	SONES	DUCT DIA.	WATTS	AMPS	CFM vs. STATIC PRESSURE (Ps) in WG		MAX Ps	VOLTS
						0"	0.03"		
VENTS 100 MA	2756	1.82	4"	17	0.18	44	37	0.17	120/60 Hz
VENTS 125 MA	2150	2.6	5"	19.2	0.21	102	90	0.18	120/60 Hz
VENTS 150 MA	2130	2.7	6"	35.5	0.4	176	158	0.196	120/60 Hz

DIMENSIONS

MODEL	DIMENSIONS				
	B	H	L	ØD	L1
VENTS 100 MA	6 1/2"	5 7/8"	3 5/8"	3 7/8"	1 1/4"
VENTS 125 MA	7 1/2"	6 13/16"	3 7/8"	3 7/8"	1 5/16"
VENTS 150 MA	8 3/8"	7 11/16"	4 1/2"	4 1/2"	1 5/16"

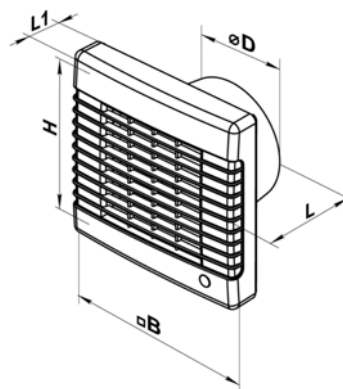

ACCESSORIES

- Air Ducts
- Grilles and Hoods
- Backdraft Dampers
- Speed Controls
- Clamps

For more information on available accessories, see pages J8-J11 in Accessories & Motors section.