



LD SERIES

Axial Fans

Axial extract LD fans are the perfect ventilation solution for modern kitchens, and bathrooms. The flat, square shaped front cover matches even the most sophisticated interior. Perfect for contemporary and modern design applications. The fans can be mounted on a wall or ceiling, and are compatible with 4", 5", and 6" ducts. No additional mounting box or special tools needed; easy installation with the help of screws and hose clamp. The fans can be connected to the supply through a switch, cord or dimmer.

Caution: The fans must not be used in bath or shower enclosures.

FEATURES

- 4", 5", 6" sizes
- Speed controllable
- Quiet and powerful
- Vibration free operation
- Easy installation
- Corrosion resistant
- UV resistant, UL94 certified plastic
- ETL listed

MOTOR

- Reliable and low-watt electric motor.
- Designed for continuous operation and requires no maintenance.
- Equipped with overheating protection.

APPLICATIONS

- Bathroom exhaust
- Kitchen ventilation
- Living area



Mounting Example

SPECIFICATIONS

MODEL	RPM	SONES	DUCT DIA.	WATTS	AMPS	CFM vs. STATIC PRESSURE (Ps) in WG		MAX Ps	VOLTS
						0"	0.03"		
VENTS 100 LD	2975	1.37	4"	13.9	0.18	44	42	0.15	120/60 Hz
VENTS 125 LD	2400	2.16	5"	15.5	0.19	79	63	0.16	120/60 Hz
VENTS 150 LD	2337	3	6"	32.9	0.39	109	92	-	120/60 Hz

DIMENSIONS

MODEL	DIMENSIONS				
	ØD	B	H	L	L1
VENTS 100 LD	6"	4 3/4"	4 15/16"	3 15/16"	1 3/16"
VENTS 125 LD	6 15/16"	5 1/2"	5 5/16"	4 15/16"	1 5/16"
VENTS 150 LD	6 15/16"	6 1/16"	6 1/16"	5 7/8"	1 7/16"

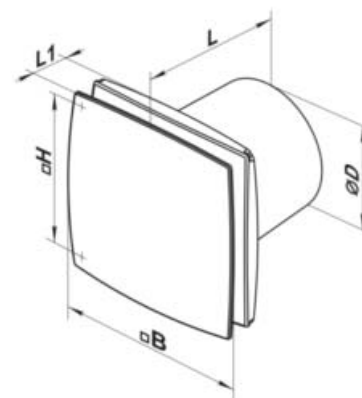

ACCESSORIES

- Air Ducts
- Grilles and Hoods
- Backdraft Dampers
- Speed Controls
- Clamps

For more information on available accessories, see pages J8-J11 in Accessories & Motors section.