

G-DD SERIES Direct Drive BLOWERS

MODELS: G9-7DD-1/3, G9-7DD-1/2, G9-DD-1/3, G9-DD-1/2, G10-8DD-1/2, G10-8DD-3/4, G10DD-1/2, G10DD-3/4, G12-9DD-3/4, G12-10-DD-3/4

Safety

Handling and installation should only be performed by trained and experienced personnel who are aware of the hazards associated with rotating equipment. Rotating parts on fans, should not be exposed. Where these components are not protected by ductwork, cabinets or covers, appropriate guards should be employed to restrict exposure to rotating parts. Access doors should never be opened with the fan running to avoid drawing in foreign objects into the system. On initial start-up, a careful inspection should be carried out to ensure no foreign material is present which could become airborne in the system.

Read installation and operation instructions carefully before attempting to install, operate or service DELHI G-DD SERIES DIRECT DRIVE BLOWERS. Failure to comply with instructions could result in personal injury and/or property damage. Retain instructions for future reference

General

Prior to installation or making any electrical connection, inspect unit for damage, loose, missing or damaged parts. Check fasteners, re-tighten as required.

Rotate the blower wheel by hand to ensure free rotation. If rubbing occurs, loosen the wheel set screw, reposition the wheel on the shaft to the center of the blower. Re-tighten set screw.

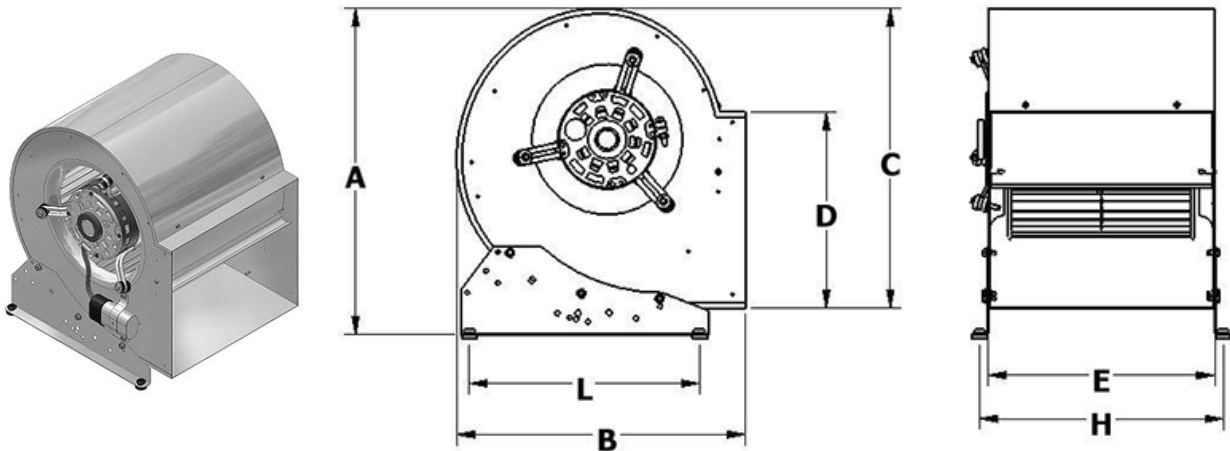

Model	Motor HP	Dimensions						
		A	B	C	D	E	L	H
G9-7-DD	1/3 or 1/2	16-15/16	15-1/16	15-9/16	10-1/4	9-3/16	11-3/4	10-3/16
G9-DD	1/3 or 1/2	16-15/16	15-1/16	15-9/16	10-1/4	11-13/16	11-3/4	12-13/16
G10-8-DD	1/2 or 3/4	19	16-3/4	17-3/8	11-3/8	10-1/2	13-3/8	11-1/2
G10-DD	1/2 or 3/4	19	16-3/4	17-3/8	11-3/8	13-1/8	13-3/8	14-1/8
G12-9-DD	3/4	22-1/8	19-1/2	20-5/8	13-7/16	12-1/4	16-1/8	13-1/4
G12-10-DD	3/4	22-1/8	19-1/2	20-5/8	13-7/16	13-1/8	16-1/8	14-1/8

Electrical

Confirm that the supply voltage is 115 volts and that all leads are clear and secure from the blower inlet. With the blower installed in the system, connect the motor at high speed, cap off unused motor leads and check the line amperage to confirm it does not exceed the Full load amps in the chart below.

If amperage exceeds Full Load Amps, substitute with a larger HP motor, or add resistance to the system to decrease air volume until the nameplate amps, or less, is obtained. Connect to desired motor speed (Hi, Med or Lo). Cap off unused motor leads.

Ensure that all electrical connections conform to applicable electrical codes.

Wiring Diagram

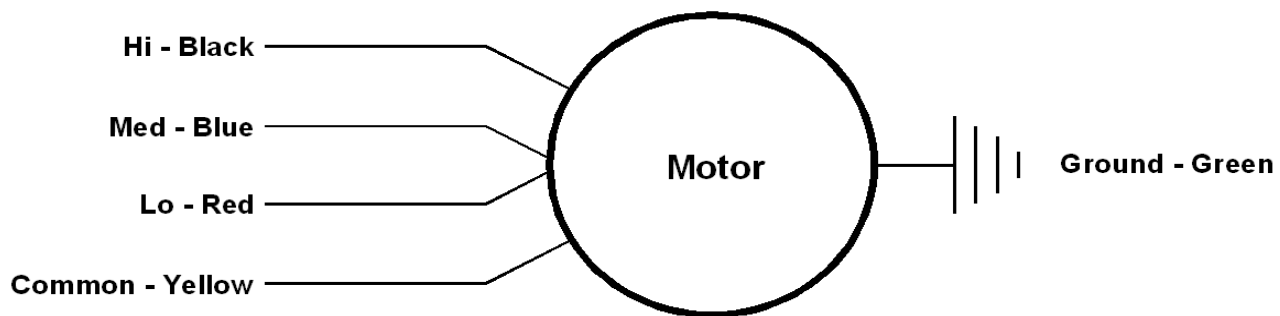

All motors are 115 volts, single phase, 3 speed, 1075 RPM		
Motor HP	Full load Amps	Capacitor
1/3	4.9	7.5 ufd
1/2	6.5	10 ufd
3/4	8.9	15 ufd



Canarm Ltd. - Corporate Head Office 2157 Parkedale Avenue, PO Box 367 Brockville, Ontario Canada K6V 5V6
Tel: (613) 342-5424; Fax: (613) 342-8437
hvacsales@canarm.ca

EC (Electronically Controlled) MOTOR SPEED CONTROL

EC motors are equipped with a control module that allows for accurate manual adjustment of motor speed. Motor speed range is from 300 to 1800rpm or maximum rpm for that model.

The control module features a 4 digit LED display that indicates % demand of full speed and motor speed in rpm. The display also indicates an error code message for minor diagnostics if required.

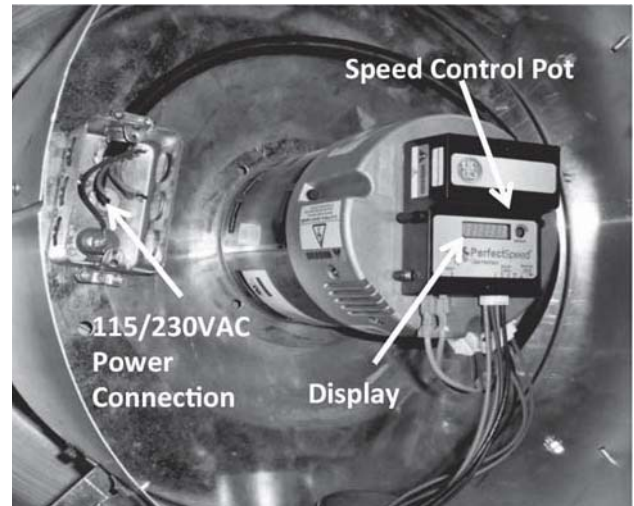

MESSAGE DISPLAYED...

- Spd-** followed by the instantaneous speed in rpm
- dE-** followed by S + demand in %
- E1-** No communications
- E2-** Under Voltage

Motor speed can be changed by adjusting the speed control pot located on the control module. A small screwdriver can be used to make the speed adjustment.

AC Supply - 115/208-230VAC

Power is connected to the motor and control module through the junction box and wiring harness provided.

Note: For 115VAC operation the blue jumper provided(taped to wire harness) must be inserted into motor power connector. See diagram.

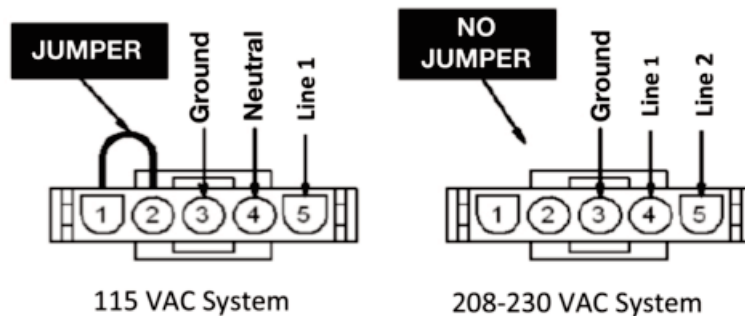

Caution: Operating the motor at 208-230VAC with the jumper will cause significant damage to the motor.

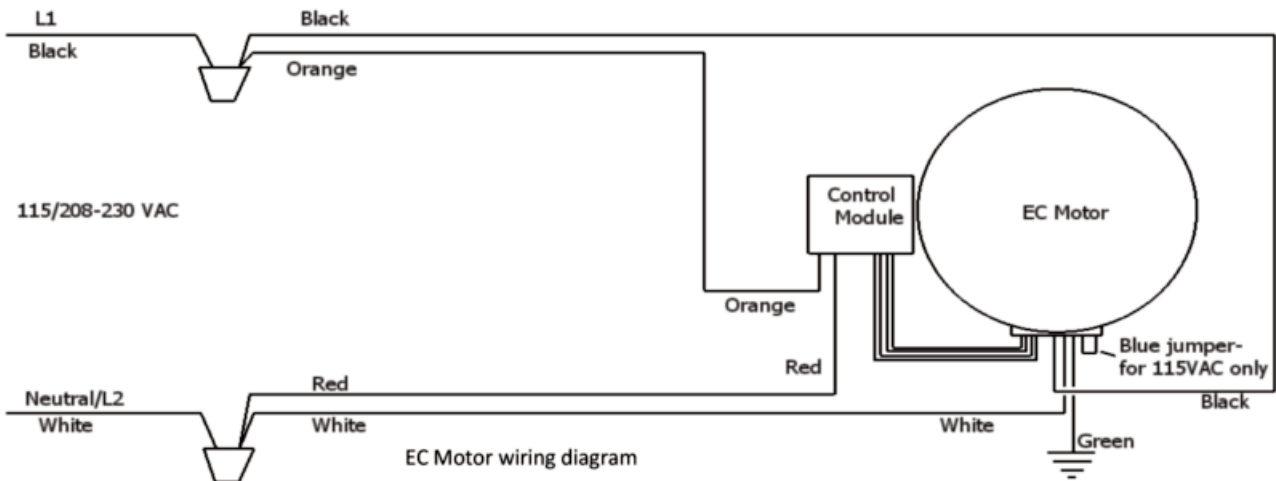

Note: EC motors have a soft start feature. When the power is turned on the control module gathers information from the motor then begins the start up process. After a few seconds the motor will start to turn and reach full set speed in 10-15 seconds.

Remote Speed Control Option (please contact factory for further information)