

CYCLONE PLUS INSTALLATION MANUAL



TABLE OF CONTENTS

1 INSTALLATION GUIDELINES FOR CYCLONE PLUS 72” FAN 2

1.1 INTRODUCTION 2

1.2 PROPER DESIGN AND INSTALLATION 3

1.3 AIRFLOW VELOCITY DIAGRAM 3

1.4 PRODUCTS RECEPTION 4

1.5 OPTIONAL ELECTRIC COMPONENTS..... 5

2 OVERVIEW OF THE PROJECT MECHANICAL INSTALLATION 6

2.1 PREPARING TO INSTALL THE FAN 6

3 MECHANICAL INSTALLATION PROCEDURE..... 7

3.1 BEFORE YOU RAISE THE CYCLONE 7

3.1.1 DIRECTIONS OF THE AIRFLOW..... 7

3.1.2 INSTALLATION OF THE AIR INTAKE..... 8

3.2 TWO STEP INSTALLATION 8

3.2.1 STEP 1 – LIFT THE CYCLONE IN PLACE 8

3.2.2 STEP 2 – INSTALL CYCLONE DEFLECTORS 8

4 DIRECTIONS FOR HANGING/MOUNTING THE CYCLONE..... 9

4.1 CEILING SUSPENDED..... 9

4.2 WALL OR COLUMN INSTALLATION..... 10

4.3 FLOOR STANDING MOUNT 11

5 ASSEMBLY REQUIRED WITH THE CYCLONE IN THE AIR..... 12

5.1 DEFLECTOR SUPPORT BRACKETS..... 12

6 ELECTRICAL INSTALLATION PROCEDURE..... 13

6.1 GENERAL NOTES FOR VARIABLE FREQUENCY DRIVE (VFD) SYSTEMS..... 13

6.1.1 MOUNTING..... 13

6.1.2 POWER WIRING 13

6.1.3 CONTROL WIRES..... 13

6.1.4 CHECK-UP BEFORE STARTING..... 14

6.2 MANUAL CONTROL SYSTEM..... 14

6.3 AUTOMATIC CONTROL SYSTEM 14

7 WARRANTY 14

8 START UP INFORMATION & DIAGRAMS..... 15

8.1 START UP PROCEDURE 15

8.2 VFD PROGRAMMING NOTES 15

9 GREASING PROCEDURE FOR CYCLONE PLUS 72 16

1 INSTALLATION GUIDELINES FOR CYCLONE PLUS 72" FAN

1.1 INTRODUCTION

Congratulations and thank you for purchasing the Cyclone Plus 72" Recirculation Fan.

The Canarm Cyclone fan is the first fan designed especially for the dairy industry and cooling cows. It transfers electrical energy into air energy and focuses the air in a controlled pattern.

It is a recirculation fan that is designed to move a large volume of air and to provide significant airspeed in the occupied zones of dairy barns or other livestock buildings (See figures 1).

The Cyclone Plus is one of the most innovative and efficient recirculation fans available on the market today.

Its main benefits are:

- It moves a large volume of air (86,000cfm);
- It creates vertical wind for cooling at floor level;
- It can run at low speed during colder times to de-stratify the air in your building.

It does all of these applications efficiently and quietly.

The cyclone can be used as a standalone ventilation system or to improve your existing ventilation. Many cyclones can be installed in the building to create significant air movement.

It is recommended to read this manual before installing the new system and you might keep it into your files because it could also be handy during and after the installation.



1.2 PROPER DESIGN AND INSTALLATION

Your sales professionals have given you a recommendation for fan placement, orientation and system operation.

This recommendation is based on tests and experience so you'll be able to get the maximum results for cooling your animals.

Typically, designs for livestock buildings are based on effective cyclones cooling areas as described in figure 2.

The installation is by design made simple for skilled tradesmen.

If you are unsure about this, please call our number for technical support **1-800-260-5314**.

We recommend you hire licensed and insured contractors to install this equipment.

It is up to you as the owner to ensure that your building is made ready for the system.

1.3 AIRFLOW VELOCITY DIAGRAM

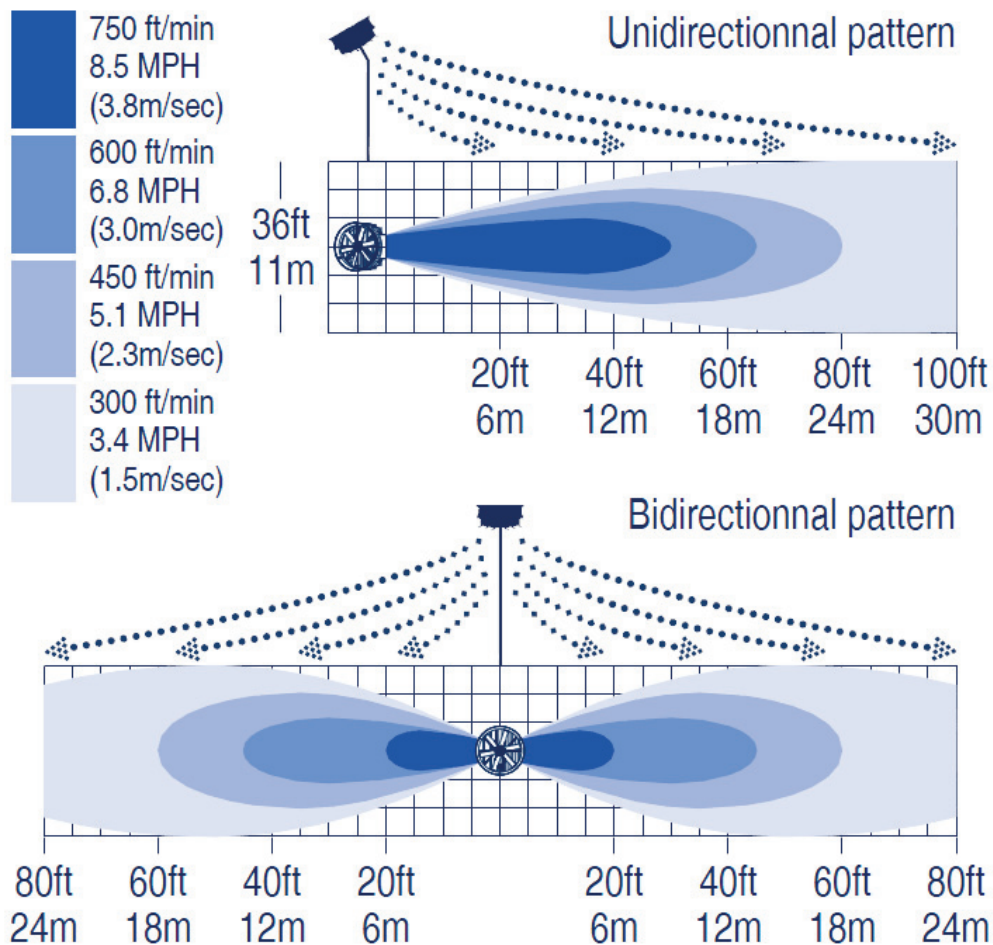

Figure 2 – Airflow velocity diagram of the Cyclone Plus 72" at maximum speed

1.4 PRODUCTS RECEPTION

We recommend you to receive this system in a coordinated and verified manner, in order to avoid lost time due to misplaced equipment.

The Cyclone is shipped in one skid.

Wood blocks between all propellers and housing

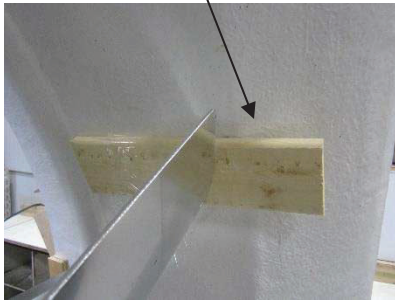

Figure 3 – Packing of the Cyclone Plus

The main units are:

1. Cyclone Plus: fan, motor, belts, sheaves, and framing are shipped as one piece and no further assembly is required.
 - Package weight is 450 lbs;
 - Weight 375 lbs without packaging and skid;
 - Skid sizes are roughly 3' L x 8' W x 8' H.
2. The deflectors, mounting hardware and deflector mounting brackets are shipped with the fan and require assembly.
3. Optional mounting units (purchased separately):
 - a. Ceiling Hung Unit (Package weight is 50 lbs);
 - b. Wall or Post Mounting Unit (#FGCY-MNTKIT) (Package weight is 200 lbs);
 - c. 30deg Angle Union for one direction airflow.

IMPORTANT NOTE: there is a piece of wood at the end of each propeller. They have to stay in place until the end of the installation in order to provide the correct gap between the propellers and the housing.

1.5 OPTIONAL ELECTRIC COMPONENTS

The Cyclone motor may be single phase or 3 phases according to your order.

Most 3 phase motors are dual Voltage, for most of these motors, Low Voltage means 230Vac and High Voltage means 460Vac.

We strongly suggest you to install a Variable Speed Drive (VFD) if it is a 3 phase type, in order to achieve the full performance of the Cyclone fan.

The VFD will allow you to run your fan manually or automatically (when connected to a thermostat) from low speed (15Hz for 60rpm) to high speed (60Hz for 245rpm).

Visit Canarm.com to view our full offering of controls.

****460VAC drives are also available on demand and require the addition of line reactors.**

You can also add one of our temperature controls that can be wired to the VFD and change the speeds based on temperature, time or humidity.

Visit Canarm.com or call our technical support line 1-800-260-5314 for a list of Canarm approved controls.

It is important that controls are sized properly for the amp loading of the fan.

ON ORDERING, CUSTOMER MUST SPECIFY THE TYPE OF POWER SUPPLY AVAILABLE INTO THE FARM IN ORDER TO GET THE GOOD MODEL OF DRIVE.

WIRING MUST BE DONE BY A CERTIFIED ELECTRICIAN, ACCORDING TO FEDERAL, STATE AND LOCAL REGULATIONS.

2 OVERVIEW OF THE PROJECT MECHANICAL INSTALLATION

2.1 PREPARING TO INSTALL THE FAN

Review this entire manual with the installation team and share information with necessary personnel.

- Physically confirm the arrangements and locations of the system cyclones and controls. Verify your order documents for the system configuration.
- There are several components that can be assembled on the floor for easier cyclone system installations.

Consult your construction professionals.

- Consult with your professional construction team and review this installation.
- Review and prepare your electrical and structural building components.

Plan to receive and store the system components.

- Check inside the freight and inspect it while the driver is present. Report any damages to the driver and your sales representative.
- Store the freight in a location that has proper access for material handling and that will keep it in good condition; avoid storing the material in corridors where tractors or other vehicles can cause damage.

All the floor work should be done in a dedicated workspace to begin the installation.

The fans have heavy eye loops for handling and hanging. The Cyclone Plus is heavy and awkward to handle. Please use caution and maximum safety when handling.

- The optional variable frequency drive (VFD) shall be resilient mounted and installed within a distance of **20 feet** from the fan.
- The VFD shall be positioned upright to allow airflow out both sides of the heat sink.
- The VFD motor wiring and terminations has to be done by licensed electricians.
- In high moisture applications a waterproof connector and drip loop in the wire should be used.
- Check sheaves and belts for alignment and tension in case they have moved during the shipping. They should be adjusted if required.
- The bearings should be inspected and greased as required. We recommend yearly greasing and maintenance. Grease nipple is located on the back of the impeller shaft.
- Inspect for defects or missing parts. Discrepancies shall be reported to the sales department.

3 MECHANICAL INSTALLATION PROCEDURE

3.1 BEFORE YOU RAISE THE CYCLONE

Inspect and check the belts, sheaves, motor, blades, housing, deflectors, brackets, controls and mounting hardware.

3.1.1 DIRECTIONS OF THE AIRFLOW

Locate installation spot and confirm if the cyclone has to be assembled for two direction airflow (See Fig 4) or for one direction airflow (See Fig. 5).



Figure 4 - Cyclone Plus assembled for two directions airflow



Figure 5- Cyclone Plus assembled for one direction airflow

Two-way airflow Cyclone Plus shall be installed level. In this case, if used with a post bracket (part#: FGCY-MNTKIT) or a steel post a straight square 4" union is required for this type of mounting.

for one direction airflow, the Cyclone Plus is installed tilted in a **30 degree** angle. In this case, if used with a post bracket or a steel post a square 4" tilted union might be required for this type of mounting.

3.1.2 INSTALLATION OF THE AIR INTAKE

If the air intake is not installed when the fan is delivered, follow these instructions otherwise skip to the next step.

Install the three pieces together with M6x30mm Mech. Screw(x6), M6 Washer(x12), M6 Lock Washer(x6) and M6 Hex Nut(x6) (See figure 6). Do not tighten the screws too much.



Figure 6 - Installation of the three pieces of the intake together

Insert the intake into the body and put it in place with the remaining M6x30mm Mech. Screw(x9), M6 Washer(x18), M6 Lock Washer(x9) and M6 Hex Nut(x9). **Make sure that you have a space of ¼ inch between the intake and the blades.**

3.2 TWO STEP INSTALLATION

3.2.1 STEP 1 – LIFT THE CYCLONE IN PLACE

- Install the top of the fan housing at more than **4 feet** to the ceiling/roof deck.
- Install the bottom of the fan shutter higher than **7 feet** above the ground.
- Do not install fans where they may affect the performance of emergency sprinkler systems.

3.2.2 STEP 2 – INSTALL CYCLONE DEFLECTORS

- The outside deflector brackets and deflectors should be installed after the fan is securely mounted in order to prevent damage to the deflectors.
- If the fan is horizontal, the deflectors should be mounted to throw the air in both fan sides (see Figure 4).
- If the fan is in angle, the deflectors should be mounted in the same direction in order to throw the air horizontal (see figure 5).

4 DIRECTIONS FOR HANGING/MOUNTING THE CYCLONE

4.1 CEILING SUSPENDED

Install the fans in the locations directed by your system provider.

Use 150# Chain or Aircraft Steel Cable that can handle minimum of **425 LBS** of hanging weight.

There are 4 eyelets installed on the fan. These metric eyelets are M10 x 75 shanks with a 30 mm loops. Standard size is 3/8" x 3" shanks x 1-1/4" loops.

Cable or chain shall be installed vertically to the ceiling at a 45 degrees angle away from the center of the fan.

Ceiling structure fasteners shall be done with Heavy Beam Clamps and 3/8" Eyelets or drilled 3/8" eyelets with heavy backing washers and double heavy nuts.

Z-Purlins may require reinforcement to prevent twisting.

Be sure to evaluate that the structure is strong enough to support the 425 LBS Cyclone Plus.

4.2 WALL OR COLUMN INSTALLATION

Wall brackets could be mounted to columns or walls (see figure 7).

Canarm can provide the steel arm kit for existing 6"x8" or an 8"x8" post fixation (part# FGCY-MNTKIT). Hardware description is provided with the kit.

A tilted union for one way airflow or a straight square 4" union for two direction airflow is required.

The fan will be cantilevered away from the mounting structure by approximately 40". Be sure to evaluate that the structure is strong enough to support the 425LBS Cyclone Plus.

As an added safety measure, we recommend adding the ceiling suspended kit when the fan is positioned in fork lift traffic areas or mounted over people.

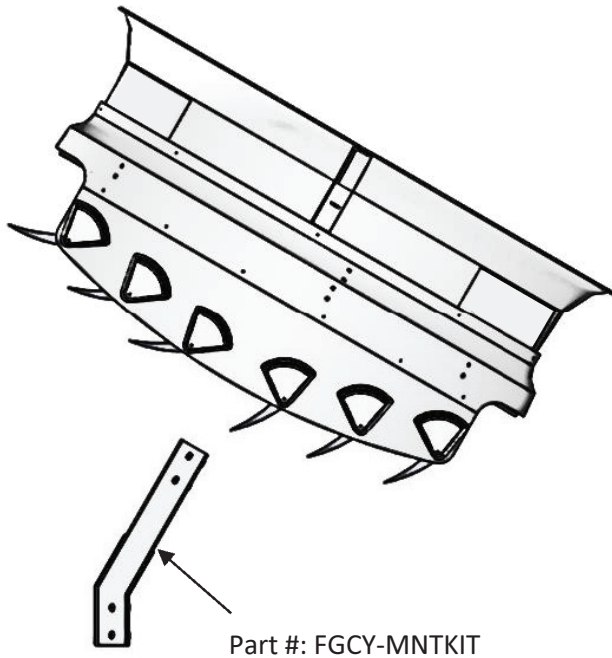

Figure 7 - Cyclone install on a column

4.3 FLOOR STANDING MOUNT

In this configuration the fan could be mounted horizontally or in a 30 degrees slope (See Figure 8).

The fan is mounted on a 4"x4" post at 12ft height measured underneath the fan.

Heavy gauge steel base, with concrete anchors, is provided for a solid mount.

Contact your Canarm rep for pricing and part numbers, or email agsales@canarm.ca



Figure 8 - Cyclone Plus install on post, horizontally and at 30 degree angle

5 ASSEMBLY REQUIRED WITH THE CYCLONE IN THE AIR

5.1 DEFLECTOR SUPPORT BRACKETS

Deflector support Brackets are to be installed inside and on opposite flat sides of the cyclone housing. The brackets are located on the sides that have a curved edge contour with holes drilled to mount the deflector brackets.

Use (12) M6 x 30mm bolts, (12) M6 hex nuts, (12) 6mm lock washers and (24) 6mm x 18mm flat washers to mount the deflector brackets.

Install the turning vanes in-between the brackets with the (24) M8 x 25mm bolts, and (24) 8mm x 25mm flat washers. Notice the difference between the "two-way" and the "one-way" airflow (See Figures 9 and 10).

Finger thread and snug these M8 bolts being careful not to over tighten. When you have completed setting the deflector angles you must wrench tighten these bolts to **no more than 20 ft.-lbs.**

Refer to fan adjustments in the start-up section.

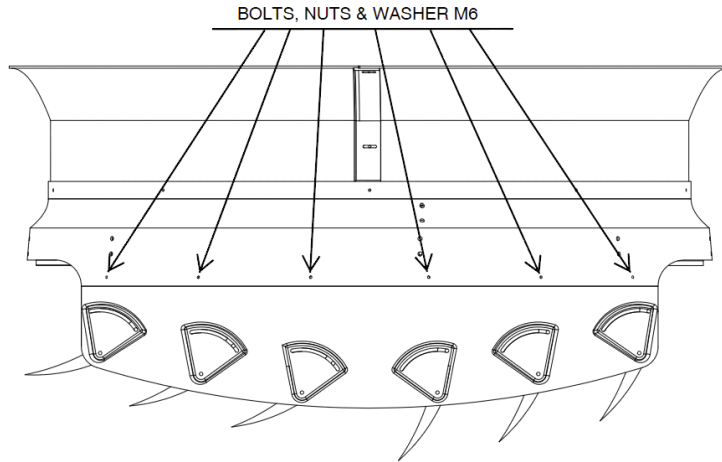

Figure 9 - Position and location of the hardware on the Cyclone Plus

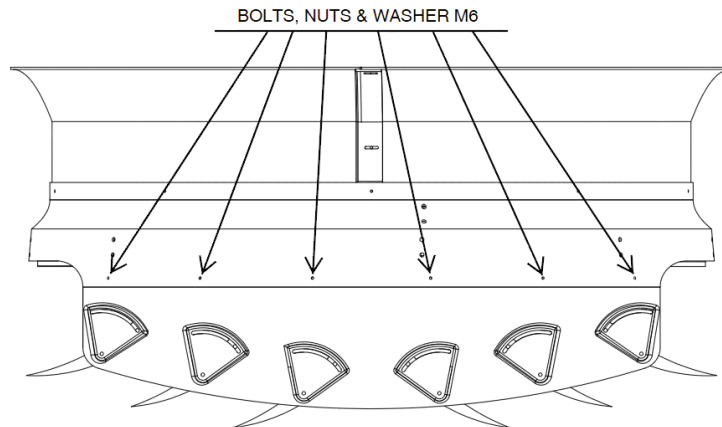

Figure 10 - Position and location of the hardware on the Cyclone Plus

6 ELECTRICAL INSTALLATION PROCEDURE

6.1 GENERAL NOTES FOR VARIABLE FREQUENCY DRIVE (VFD) SYSTEMS

6.1.1 MOUNTING

- Mount the drive as close as possible to the motor to be controlled (**20 ft. or 6m MAX.**);
- Mount the drive in a location that will insure easy access and will avoid all contact with water;
- Allow 12" free space all around the drive for heat dissipation;
- Do not mount the drive close to heating units or elements;
- Do not use any power correction or surge protection device, at the drive output;
- Do not use any switching device at the drive output;
- Do not mount the drive close to magnetic detection system.

6.1.2 POWER WIRING

(Refer to the wiring diagram supplied with the VFD)

- When servicing, wait at least 3 minutes before interfering with wiring, in order to allow capacitors discharge;
- Use only non-metallic conduit to run the wire between the electrical panel and the drive, or between the drive and the motor;
- Use power wire copper type, 600V,105C, USA or Canada, REW, XLPVC or TEW;
- Size all conductors for 3% voltage drop;
- Run a circuit exclusively for the drive;
- Physically split input and output wiring of the drive;
- On humidity applications we recommend using water tight connectors and installing a drip loop on the motor;
- The current required for the VFD and Motor is different for the various typical voltage systems;
- Size the OCP (Breaker or Fuse) per the VFD manufacturer's instructions and per the Code;
- Always refer to the VFD manufacturer's installation manual for specific details;
- The VFD is rated IP 55. Consult your electrical contractor and the VFD manufacturer for input regarding multiple VFD branch circuits and potential for input line reactors.

6.1.3 CONTROL WIRES

(Refer to the wiring diagram supplied with the VFD)

- Use only shielded cable for control signal connections (4 conductors);
- There are two control signals from the temperature controller:
 - 0-10VDC-from control terminals S+ and S-;
 - The start-up signal from control terminals E-F.
- Shield should be connected at one end only;
- The low voltage wiring shall be separate from the power wiring. This is a 0-10V DC analog signal.
- Do not run control cables along with power cables;
- Keep a minimum distance of 3" (7cm) between control and power cables at all time;
- If needed, cross control and power cables at 90 degrees.

6.1.4 CHECK-UP BEFORE STARTING

- Verify that all wood shims are removed at the end of each blade of the propeller.
- Make sure there is no condensation or risk of condensation into the controller.

GROUNDING IS VERY IMPORTANT FOR PEOPLE AND ELECTRONIC SAFETY.

- Be sure that the building's electrical system is properly grounded.
- VFD Note: There are 2 grounding points that are each marked PE. Land the motor ground lead and the mechanical ground lead properly!
- Be sure to terminate the ground systems per the VFD instruction manual.

6.2 MANUAL CONTROL SYSTEM

Requires one Class 2, 3-conductor PLC cable connected between the VFD and the remote speed control. The VFD provides the 10V DC power source for this 3-wire control loop.

- Use AWG #22 stranded copper conductors for distances up to 100';
- Use AWG #20 stranded copper for distance up to 500', and;
- Use AWG #18 stranded copper for distance up to 1000'.

6.3 AUTOMATIC CONTROL SYSTEM

Specific directions will be provided for the Automatic Control System Options.

7 WARRANTY

CANARM Ltd. warrants every new fan to be free of defects in material and workmanship, to the extent that, within a period of one year from the date of purchase CANARM Ltd. shall either repair or replace at CANARM's option, any unit or part thereof, returned freight prepaid, and found to be defective.

This warranty does not include any labour or transportation costs incidental to the removal and reinstallation of the unit at the user's premises.

Components repaired or replaced are warranted through the remainder of the original warranty period only.

This warranty applies to the original purchaser-user only; it is null and void in case of alteration, accident, abuse, neglect, and operation not in accordance with instructions.

NOTICE: No warranty claims will be honored by CANARM Ltd. unless prior authorization is obtained.

8 START UP INFORMATION & DIAGRAMS

8.1 START UP PROCEDURE

- Check that the power is turned off.
- Check VFD and Wiring Terminations for tight connections.
- Verify that the VFD is clean and dry.
- Test power wiring for short and open circuits.
- Ensure that suspension cable clamps or chain links are tight and closed.
- Ensure the fasteners of the wall or post supports are tight.
- Check that the cyclone and the circuit breaker or fuse clip is labelled.
- Ensure that the fan turns freely and is quiet. Check the belts too.
- Clear the area around and below the Cyclone.
- Energize the power circuit.
- Test the voltages at the drive and record them. Program the VFD per the VFD instruction manual. See programming notes below.
- Jog the fan motor on and off to ensure the proper rotation. The fan will turn clockwise looking underneath the fan.
- **Note: If the fan blade turns counter clockwise, you will need to de-energize the fan and wait for the VFD to discharge. Then reverse two of the motor wiring phase terminals leads. Jog the fan again to ensure the proper rotation.**
- Start the fan and check the airflow.
- Setting the airflow. The deflector vanes can be adjusted to direct the air stream. Allow 2-3 minutes for air flow stability before making more adjustments.
- Check the settings of drive according to the following tables;
- Check the operation of the VFD and fans with the GENSET ON.

8.2 VFD PROGRAMMING NOTES

By default, VFD should be programmed for the installation and ready to operate right off the box. .

In case of trouble, refer to the VFD Instruction Manual before programming VFD or call Canarm Service department at **1-800-260-5314**.

A 3HP, 85% efficiency, 3-phase, 1760RPM, totally enclosed, fan cooled, alternating current motor drives the cyclone fan. Verify the nameplate data of the motor and note this information to use in programming the VFD parameters.

9 GREASING PROCEDURE FOR CYCLONE PLUS 72

This following greasing procedure applies only to the Cyclone Plus 72. **This procedure must be done each year.**

Required material :

- Grease gun
- Lithium grease



Figure 1 : Grease gun

STEP 1: Locate the grease fitting on the end of the propeller shaft, in front of you.

END OF PROPELLER
SHAFT

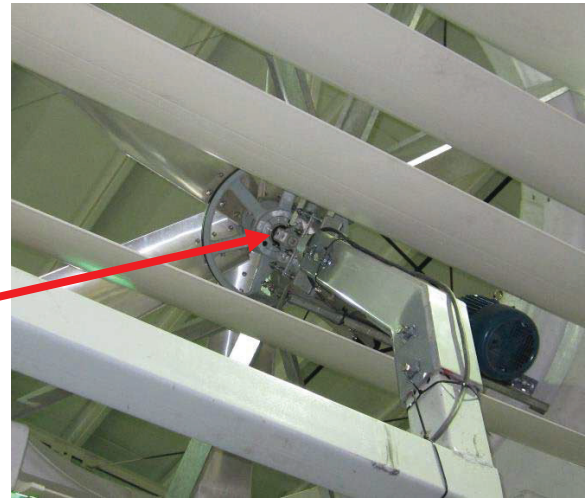

STEP 2: Insert grease with the grease gun in the grease fitting as shown in the picture below.

RACCORD DE
GRAISSAGE/ GREASE



