



# Bottom Roll-Up

INSTALLATION MANUAL



P.O. Box 279  
Shakespeare, ON  
NOB 2P0

1-800-960-4002  
[www.faromor.com](http://www.faromor.com)

November 2015



# Table of Contents

Page 3	-	<b>Introduction</b>
	-	<b>General Considerations</b>
Page 4	-	<b>Framing Details</b>
Page 5	-	<b>Parts List</b>
Page 6-19	-	<b>Installation Instructions:</b>
		<i>Page 6: Aluminum curtain track</i>
		<i>Page 6: Windrope screweyes</i>
		<i>Page 7: Curtain material</i>
		<i>Page 7: Inside end pocket</i>
		<i>Page 8: End pocket - general</i>
		<i>Page 8: Outside end pocket</i>
		<i>Page 9: End pocket with track</i>
		<i>Page 9: End pocket completion</i>
		<i>Page 10: Manual drive unit</i>
		<i>Page 10-14: Power drive unit and Pocket Installation</i>
		<i>Page 15: Wind protection systems</i>
		<i>Page 15: Wind rope installation</i>
		<i>Page 16: Wind Pipe</i>
		<i>Page 16: Inside and outside wind pipes</i>
		<i>Page 17: Outside wind pipes only</i>
		<i>Page 17: Split double wind pipe</i>
		<i>Page 18: Limit switch</i>
Page 19	-	<b>Finishing Tips and Touches</b>
Page 19	-	<b>Warranty Policy</b>



# Introduction

Bottom Roll-Up curtains open from the bottom up by wrapping itself around an aluminum tube attached at the bottom of curtain. As the pipe rolls, the curtain supports the weight of the pipe keeping it under tension and raising it under continuous tension.

The system eliminates the need for lift cables and pulleys which can give rise to maintenance problems on large barns. It also provides all the advantages of eliminating water entrapment, rodent infestation and storage under the building overhang protecting from ultra-violet degradation.

## General Considerations

**\*\*Please read the following notes prior to installing the Bottom Roll-Up Curtain:  
(For installation purposes, this manual shows “typical” installation with inside screen and outside wind ropes)**

- 1) Verify framing details are correct, as per page 4, to assure installation will work properly.
- 2) Read all instructions prior to beginning installation to familiarize yourself with parts and terminology.
- 3) Confirm what appendixes are required for your specific installation (manual vs automatic, wind ropes vs wind pipes, etc.)
- 4) Watch for “Faromor Tips” on installation pages for pointers that will assist with installation.
- 5) Please read final page “Finishing Tips and Touches” before completing installation.

# Framing Detail

## HEAVY DUTY ALUMINUM ROLL UP CURTAIN

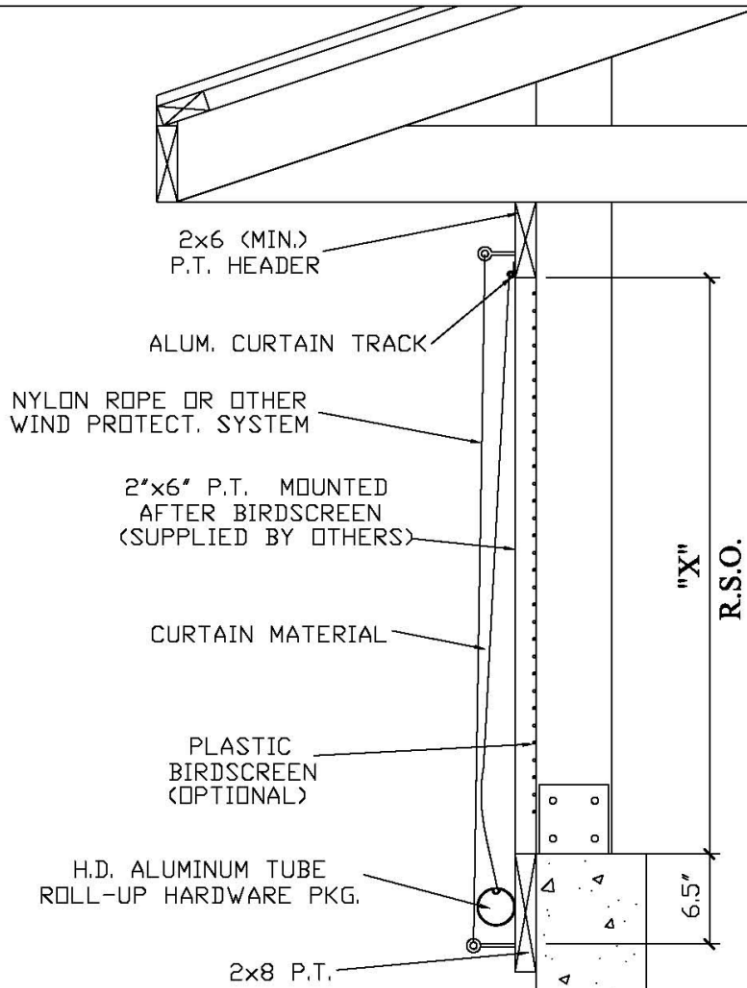

FRAMING OPENING:	
CURTAIN SIZE:	ROUGH SIZE OPENING ("X")
6 FT.	5'-6"
7 FT.	6'-6"
8 FT.	7'-6"
9 FT.	8'-6"
10 FT.	9'-6"
11 FT.	10'-6"
12 FT.	11'-6"

**FAROMOR**

P.O. Box 279, RR#1  
Shakespeare, Ontario.  
NOB 2P0 - (519) 625-8000

**TITLE:** HEAVY DUTY ALUMINUM ROLL-UP CURTAIN (POST ON CONCRETE)

**PROJECT / OWNER:**

**DRAWN:** FEBRUARY 2004

**DWG. FILE:** 04-2200-R-P-C

# Parts Listing

Item #	Part #	Description	Picture
1	04-241-03 to 04-241-12	End pocket with track	
2	04-241-03-01	End pocket "U" bracket	
3	04-241-03-02	End pocket bracket	
4	04-241-03-03	Tube holder bracket	
5	08-230-01-09	Aluminum tube	
6	04-143-03	3' curtain material - double rope	
7	ALCURTRACK	Aluminum track for gear box	
8	MTRACKSEAL	Gray rubber moulding	
9	BSCB5161 and NSHN516FF	5/16" x 1" s.s. carriage bolt and 5/16" s.s. hex nut	
10	BZHLB14X112 and SZWS14112TA	1/4" x 1-1/2" hex head lag and #14 x 1-1/2" pan soc head - zinc	
11	04-242-03 to 04-242-12	Outside Plain Pocket	
12	04-243-03 to 04-243-12	Inside end pocket (6' wide x curtain height + 1')	
13	WGRIP10X1WW	#10 X 1 w/w woodgrip screws	
14	MEB38412 MEB5154 MEL5156 MSE551010	Screweyes	
15	09-200-65-04	Galvanized motor cover	
16	08-230-01-08	Tube joiner for 2" tubing	

Item #	Part #	Description	Picture
17	R316X34SF	Small head aluminum rivet	
18	08-230-01-02	#5 nylon wind rope	
19	08-232-25-03	Bottom L Bracket for 2" Pipe Complete	
20	ST12SCH40 GALV	1/2" galvanized wind pipe	
21	08-230-25-02	Top "L" bracket	
22	08-231-25-04	Centre bracket for split wind pipes	
23	08-230-25-06	"Foot" bracket	
24	08-130-21	Aluminum curtain track	
25	SZ121TEK	#12 x 1 ind hex washer self-drill	
26			
27			
28			
29			
30			
31			
32			

# Aluminum Curtain Track Installation

**\*\*Note:** The track should be mounted on the top header with the flat part against the wood and towards the top. The bottom of the track should be flush with the bottom of the header.

Illustrated is the inside pocket. For inside pocket installation, see page 7.

Each length of track should butt up against the last piece, keeping in line with each other.

Track should be mounted to wall using screws #SZ121TEK provided at intervals of 12"

First track should start half way onto the inside pocket.

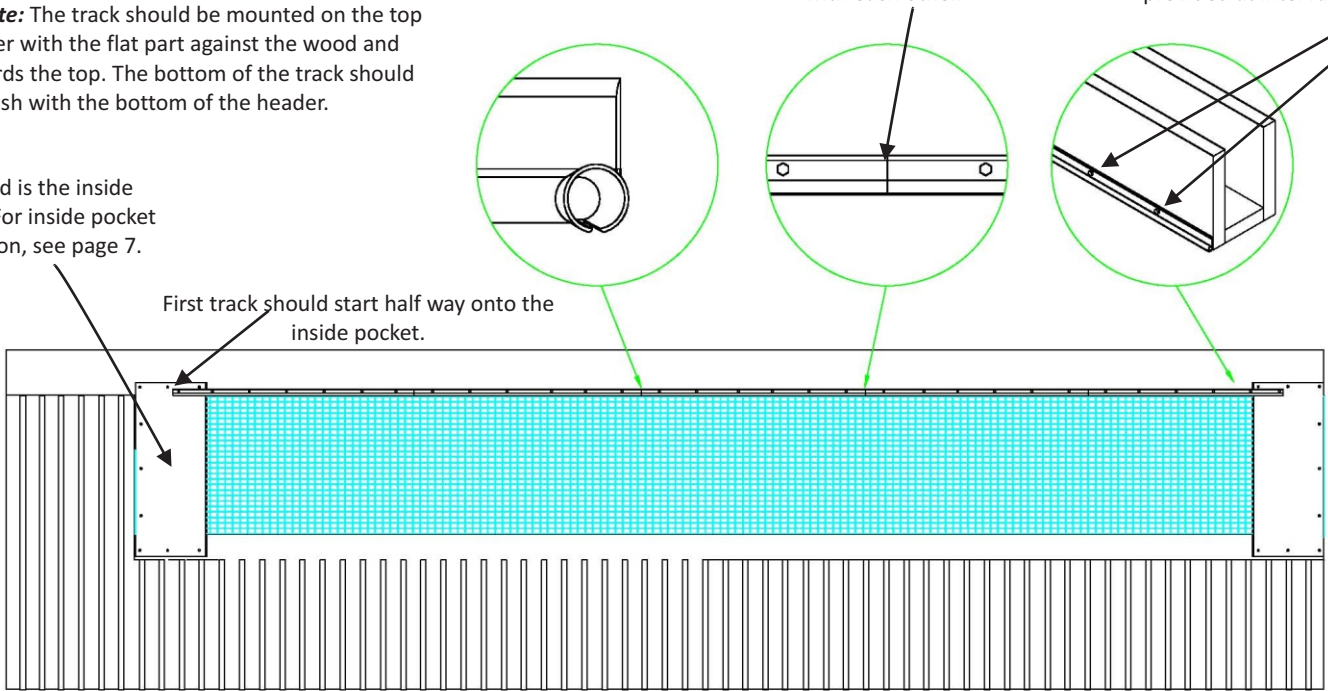

**Faromor Tip:** 1) It is **critical** that prior to mounting track, a line is chalked on the header to keep aluminum track **straight**.  
2) Decide which end the curtain will be pulled into the track from and open the mouth of the track at the corresponding end of each piece.

# Wind Rope Screweye Installation

**\*\*If a wind protection system other than wind ropes is being used, please refer to pg. 13 for installation details.**

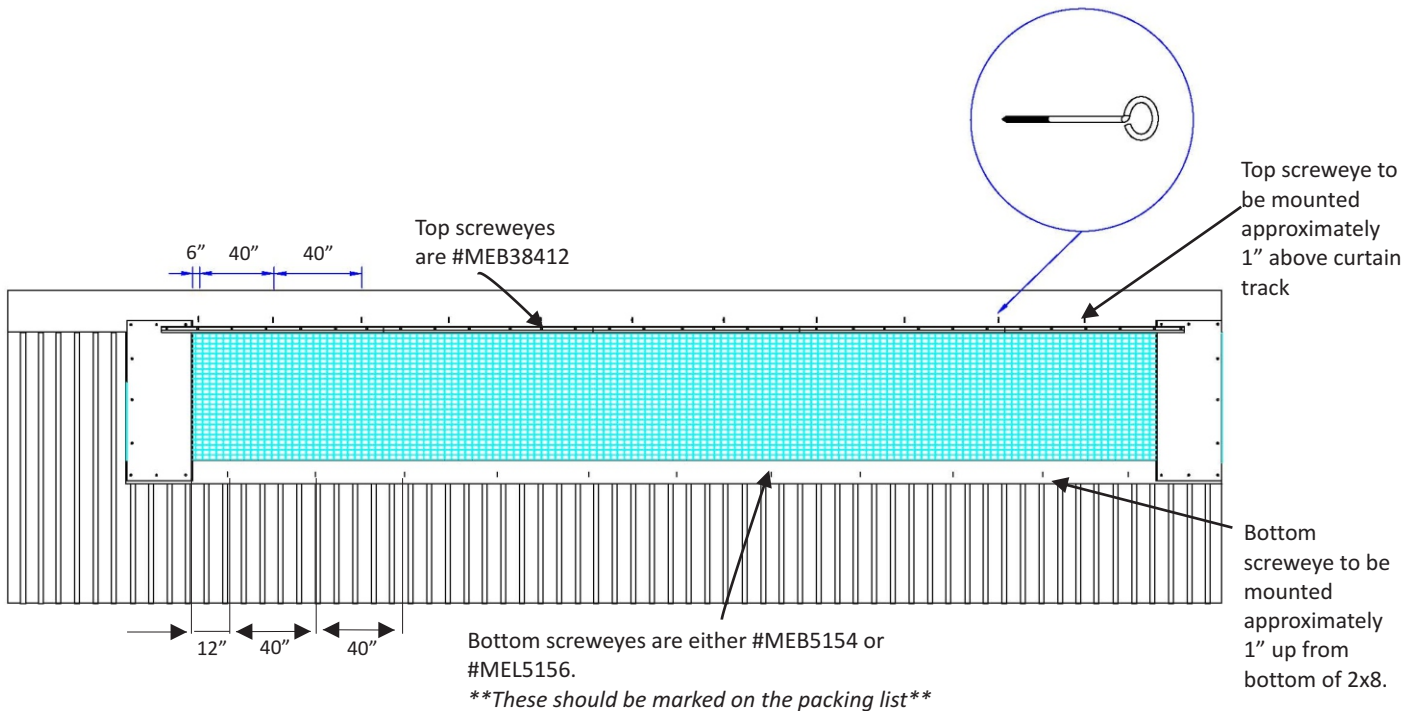



# Curtain Material and Bottom Tube Installation

**Step 1:** Sewn into the top and bottom of curtain material is a nylon rope. Begin sliding rope/curtain material into aluminum track. Keep short fold of curtain to the inside. Slide curtain to far end of track so curtain is fully unrolled. If curtain material is too long it can be cut to size.  
**\*\*See Faromor Tip**

**Step 2:** Take one length of 2" aluminum tube, slide onto bottom rope/curtain material all the way to the other end. Now insert accompanying joiner into tube and fasten with pop rivet. Slide next piece of aluminum tube onto curtain and butt two pieces of aluminum tube together and fasten second piece to joiner. (joiner should be fully enclosed). Continue in this fashion for entire length of bottom tube.

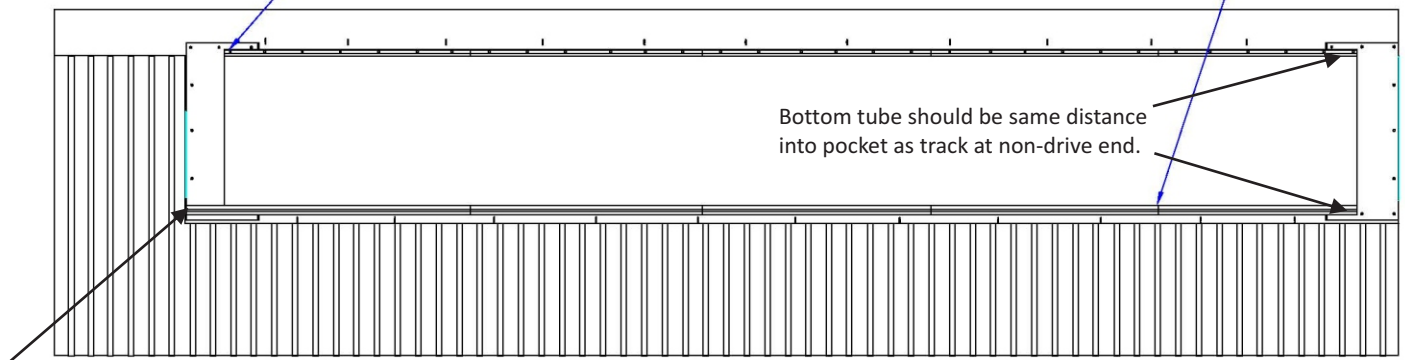
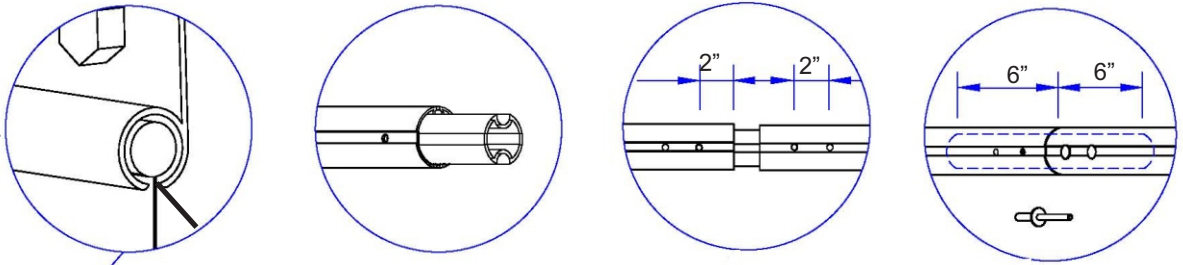

Bottom aluminum tube should extend to outside of end pocket at drive end only.

**Faromor Tip:**

1) To prevent curtain from moving while installing bottom tube, fasten rope/curtain to top aluminum track by screwing self-drilling screw through rope into aluminum at one end.

## Inside End Pockets

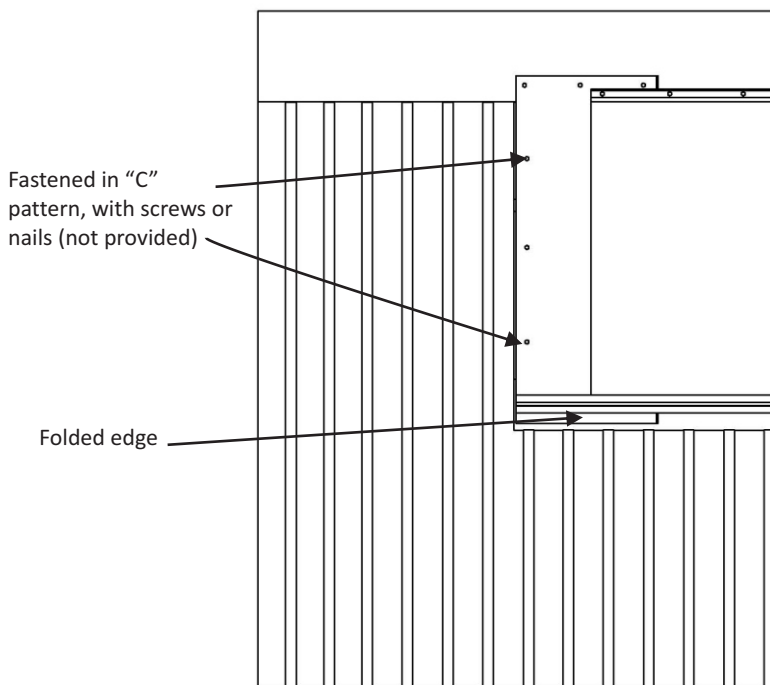

Inside end pockets are the same for any style of curtain.

The inside flap is 6' wide material that is folded in half to make a 3' wide inside pocket. The height of the pocket will be one foot longer than the height of your curtain; e.g. 4' high curtain requires 5' high end pocket.

The inside flap should be mounted at both ends of the curtain opening. The folded edge is to the interior of the opening. (See diagram)

You must fasten the material to the wall along the top, the outer edge, and the bottom in a "C" pattern. (see diagram)

# End Pocket Installation

## GENERAL

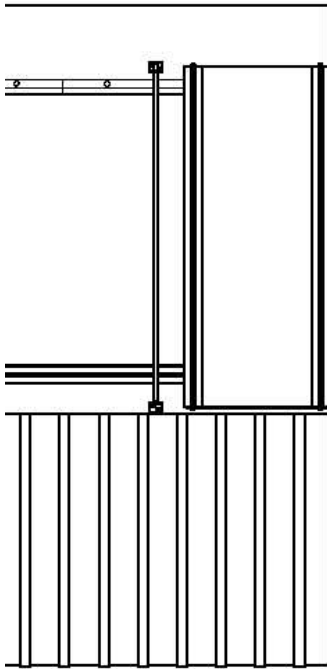

Inside end flap must be installed first.

The height of a pocket is one foot higher than curtain height.

Outside end pockets are determined by curtain styles. There will either be two plain pockets (as shown here); or one plain and one pocket with tracks.

For plain outside end pocket assembly, see page 13.

For pockets with tracks, (used with split curtain installations), see page 9.

**\*\*Please note: For Roll-A-Way curtains and Standard Top Down curtains on a split curtain system, you must use an end pocket with track to match end pocket with track on bottom curtain.**

---

## Outside End Pocket

36" wide pocket fabric must slide into both aluminum tubes. You must screw through the rope into aluminum tube to secure using screws provided.

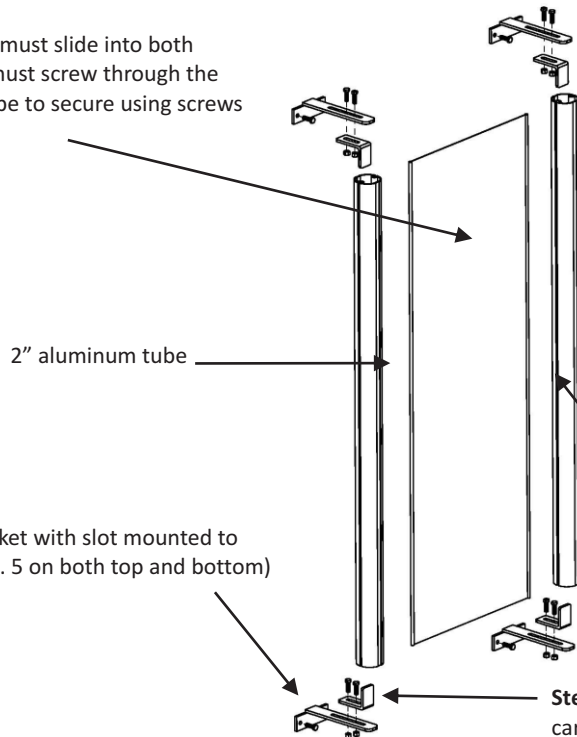

**Step 1:** End pocket bracket with slot mounted to wall (using Item #10, pg. 5 on both top and bottom)

The outside pocket is mounted at the end of the curtain opening.

If your curtain system requires a bottom roll-up gearbox, the plain outside pocket goes to the non-drive end.

The outside pocket will line up directly over top of the inside pocket.

The pocket can be adjusted on the slot bracket as required. Be sure to leave enough room for the rotating bottom tube to operate properly at bottom of opening.

**Note:** For location of brackets, mount end bracket set to the wall, flush to the edge of curtain opening. Slide curtain into this end track set, stretching fabric tightly to slide into inside tube and bracket set. Use this tube as a guide for mounting second bracket set.

**Step 2:** Tube holder bracket mounted to slot bracket using carriage bolts provided. (Item #9, pg. 5)

**\*Note:** Nuts should be at the underside of bracket

# End Pocket with Track

**Step 5:** Gray rubber moulding slides into each track and overlaps. The convex rubber fingers should overlap for a good seal.

**\*\*Note:** Use level to make sure tracks are plumb.

**Step 4:** 36" wide pocket fabric must slide into both aluminum tubes. You must screw through the rope into aluminum tube to secure using screws provided. (Need to fasten at top only)

**Step 3:** Track mounted to "U" bracket using 1/4" bolt and nut provided

**Step 1:** End pocket bracket with slot mounted to wall using Item #10, pg. 5, on both top and bottom.

**\*\*Note:** See page 18 for bracket installation measurements.

**Step 2:** End pocket "U" bracket mounted to slot bracket using carriage bolts provided. \*Note: Nuts should be at the underside of bracket

The outside pocket is mounted at the end of the curtain opening.

If your curtain system requires a bottom roll-up gearbox, the plain outside pocket goes to the non-drive end.

The outside pocket will line up directly over top of the inside pocket.

The pocket can be adjusted on the slot bracket as required. Be sure to leave enough room for the rotating bottom tube to operate properly at bottom of opening.

**Note:** For location of brackets, mount end bracket set to the wall, flush to the edge of curtain opening. Slide curtain into this end track set, stretching fabric tightly to slide into inside tube and bracket set. Use this tube as a guide for mounting second bracket set.

Tube holder bracket mounted to slot bracket using carriage bolts provided

Aluminum track

---

# End Pocket Completion

To complete the end pockets, we must now close in the very end of the sections. On either style of end pocket (with or without track) you will have a groove in the aluminum at the outermost edge to allow curtain material to slide in. Use one foot wide curtain material with rope and slide into track or tube.

Make sure curtain material reaches top to bottom, pull material onto framed opening and fasten to wall using plastic nailer strip and woodgrips provided. Trim off excess curtain material as required.

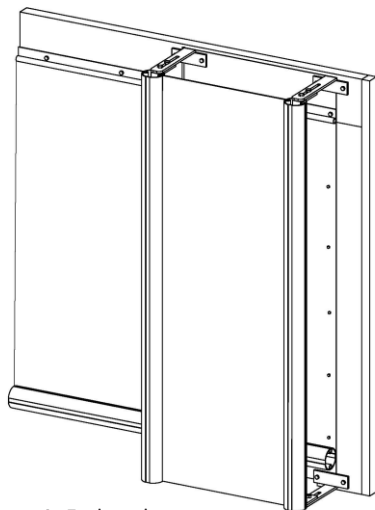

**Step 1:** End pocket before installation of fabric closure strip.

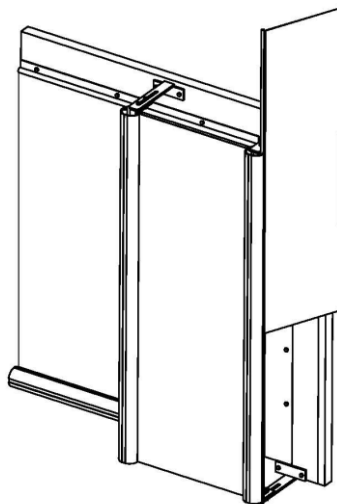

**Step 2:** Install fabric end closure strip - slide into aluminum tube from top or bottom.

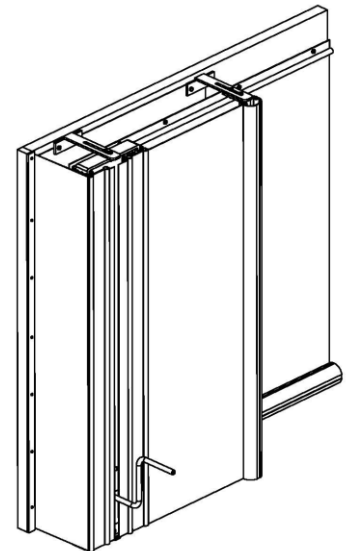

**Step 3:** Install plastic or wood nailer strip. (Can be mounted as shown or wrapped to outside to hide strip)

# Manual Drive Unit Installation

Manual drive units are interchangeable from right-hand to left-hand.

\*\*Illustration is for a right hand drive unit

Gear box drive unit is mounted into the outermost track on the end pocket.

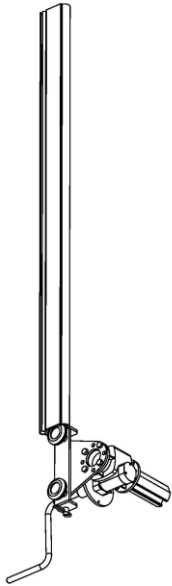

**Step 1:** Insert gear box wheels into track at bottom of pocket ensuring that the handle is to the outside of the pocket.

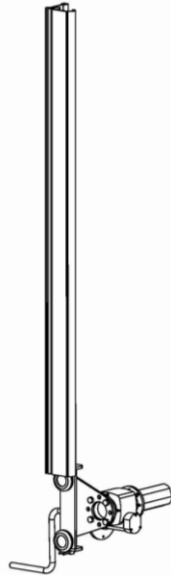

**Step 2:** Reconnect track to end pocket to contain gear box. Slide bottom aluminum tube over plastic adapter until it butts up to flange. On flat part of tube use self-tapping screw provided to secure tube to adapter.

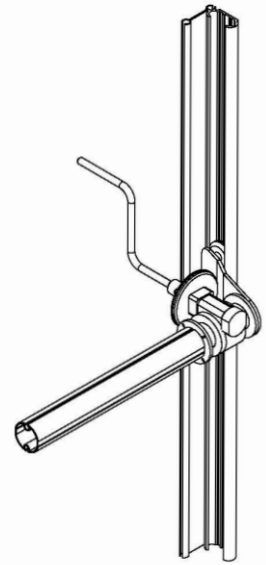

*Rear view of completed gear box installation.*

---

## Power Roll-up Drive Unit and Pocket Installation

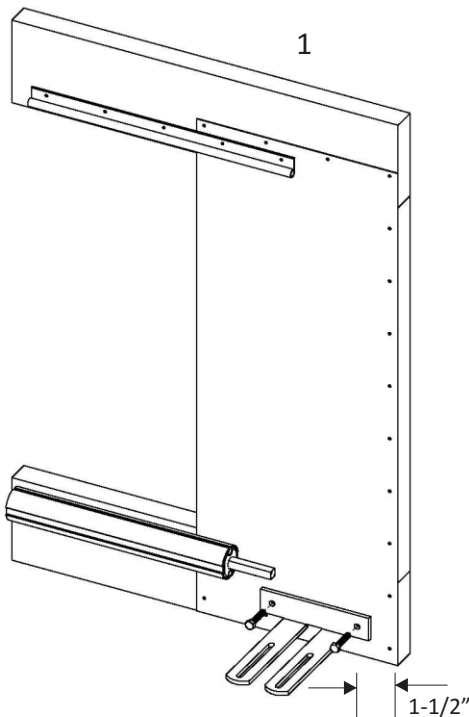

Fasten BRU double bracket to all 1-1/2" from end

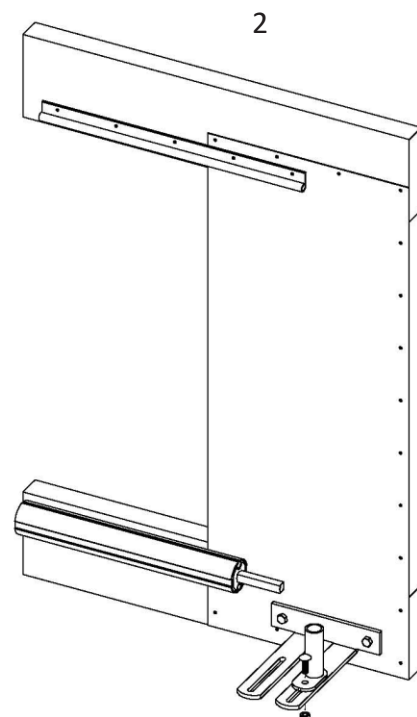

Bolt pipe adapter to BRU bracket

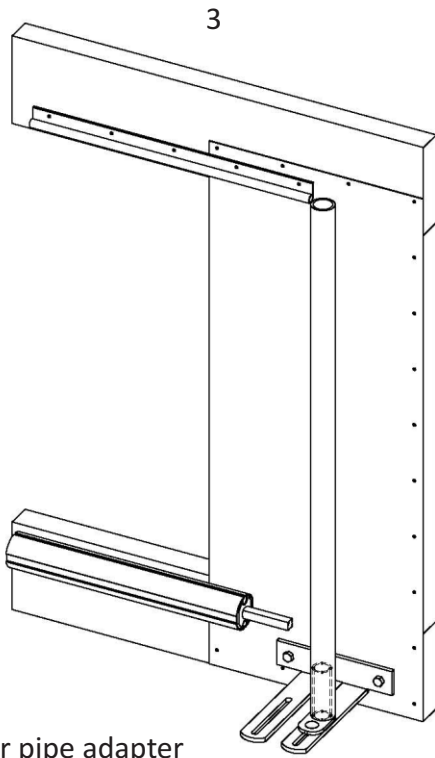

Slide pipe over pipe adapter

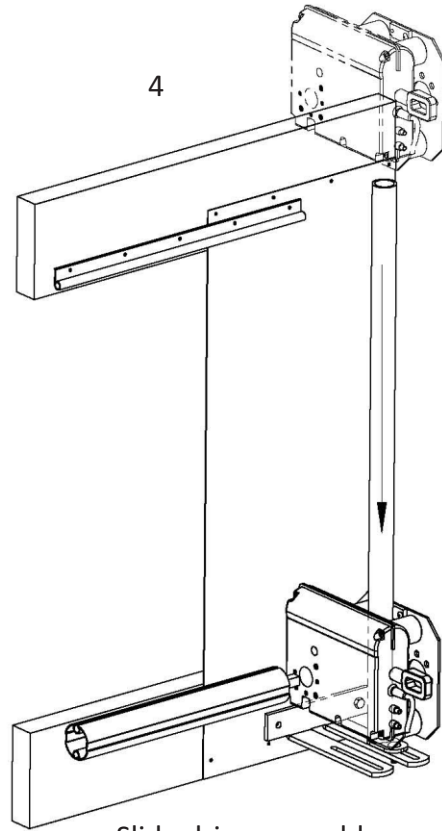

Slide drive assembly over pipe to bottom bracket

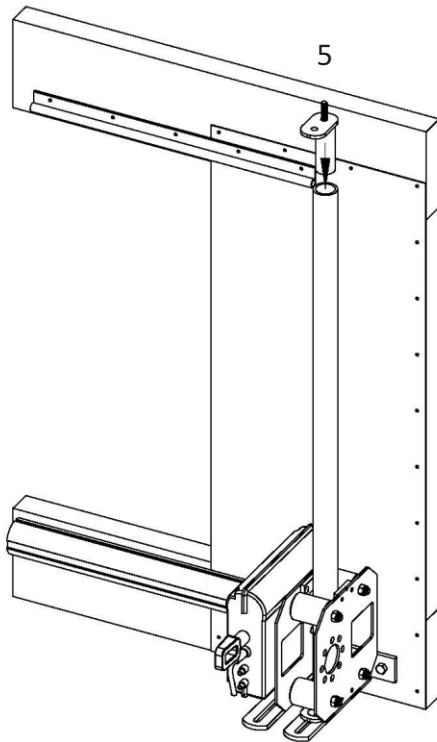

Insert top pipe adapter into pipe

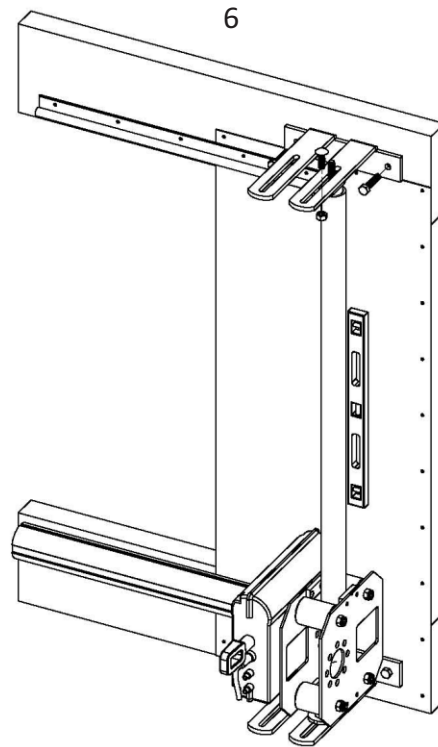

Fasten top BRU double bracket to pipe adapter (cut pipe to suit). Using a level make sure pipe is plumb and fasten bracket to wall

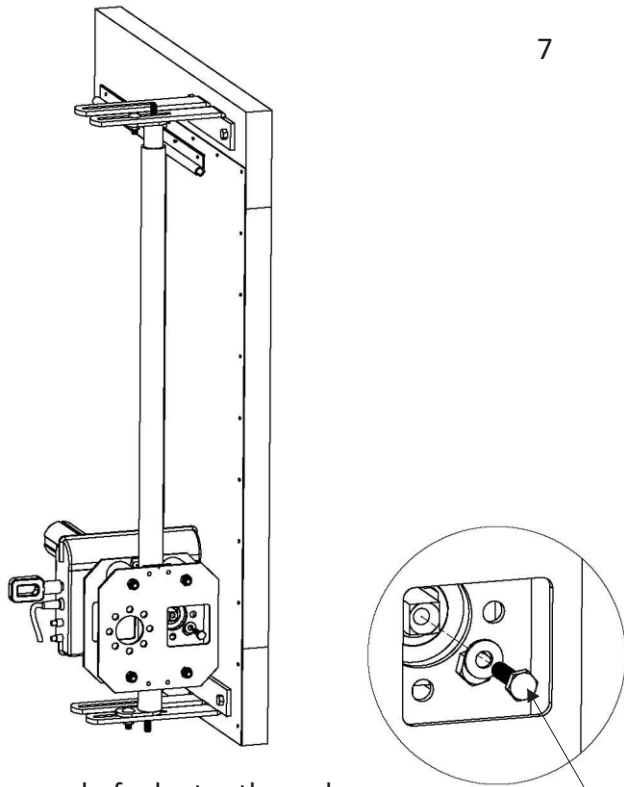

7

Slide square end of adapter through square opening in motor and fasten with bolt

- bolt number  
- washer

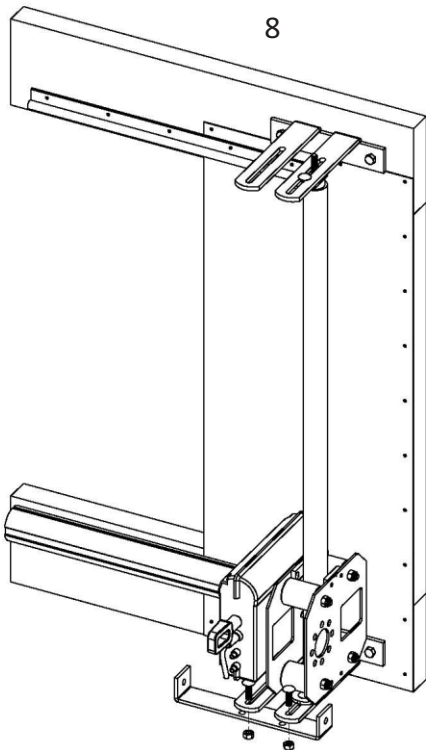
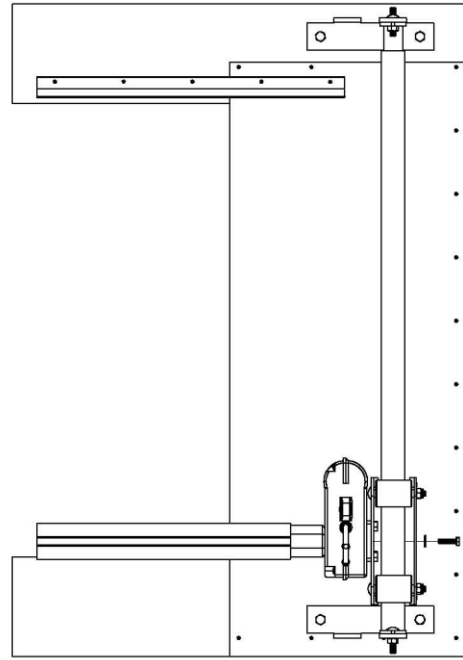

8

Bolt 09-202-65-07 bracket to Bru double bracket  
(Note: use inside holes)

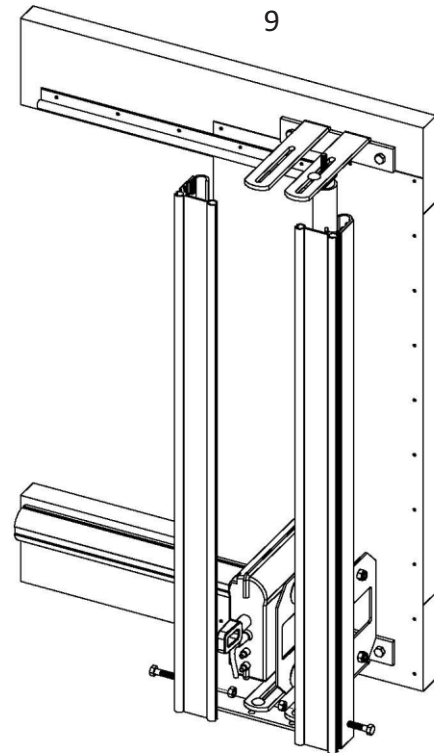

9

Drill and fasten track to bottom bracket

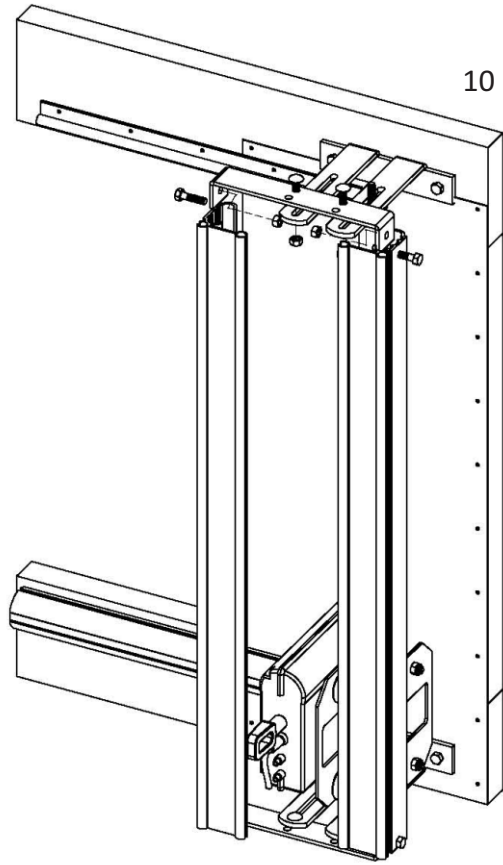

10

Slide top bracket into track. Drill and bolt together

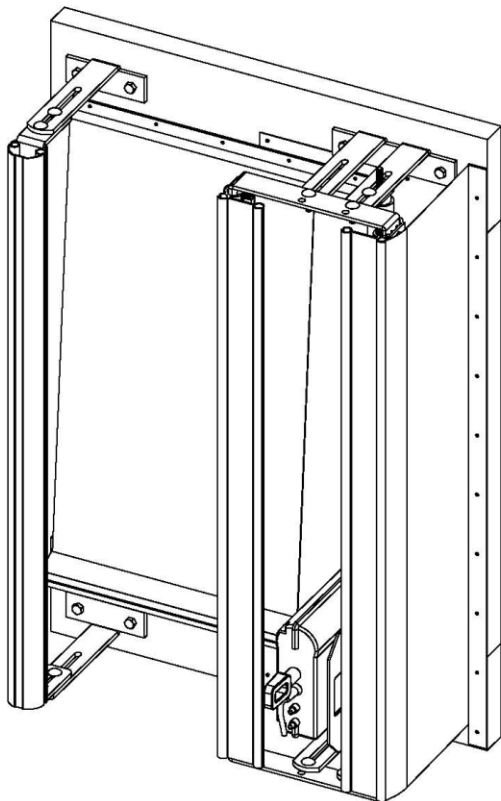

11

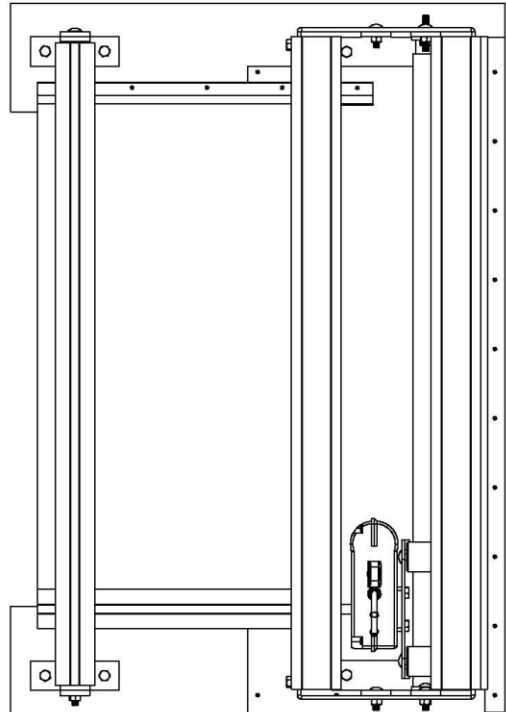

Slide end flap in track. Anchor to wall with nailer strip.



12

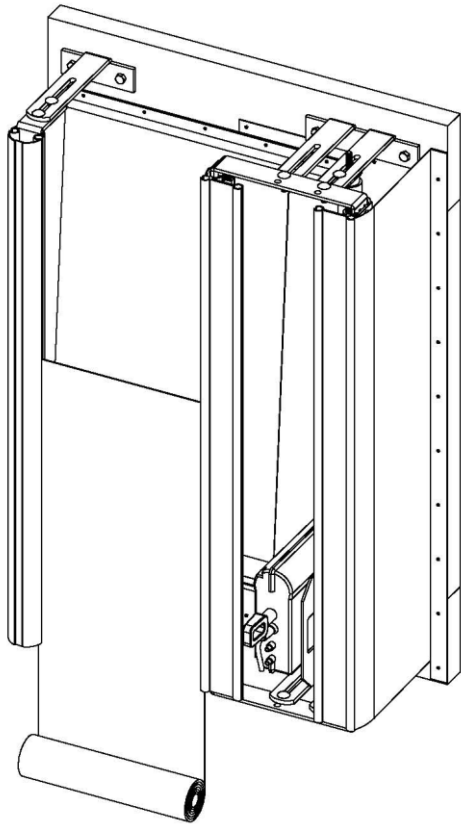

Slide pocket material into track. Anchor top (both sides).  
Pull down on material and anchor bottom (both sides).  
Cut to length





# Wind Protection Systems

## Inside Wind Protection System Options

**\*\*If installing birdscreen, it should be done first.\*\***

However if using inside wind rope system it can be installed at the same time as outside wind rope on pg. 13.

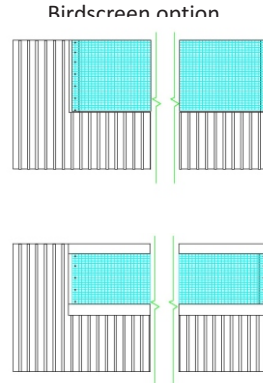
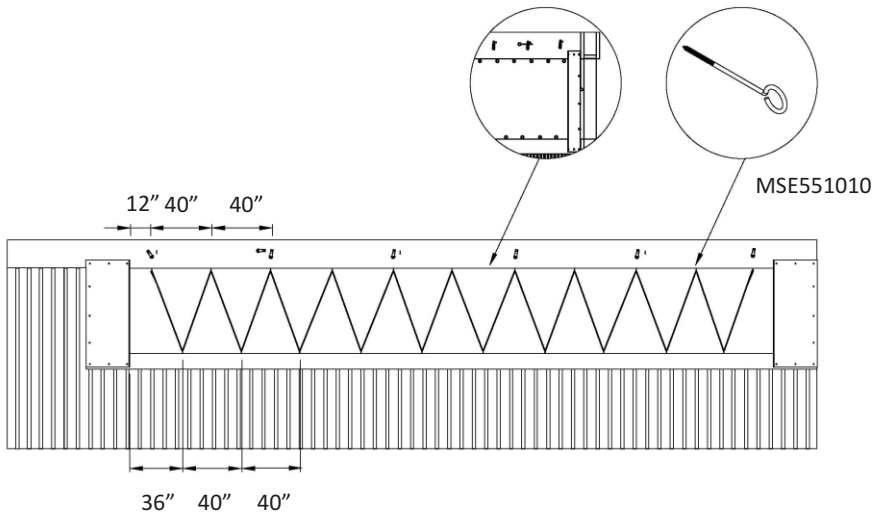

Birdscreen should be installed prior to top header and bottom board and should be installed from one end of opening to the other. To install birdscreen, fasten at one end of opening using galvanized roof nail (not supplied). Stretch roll to next post and fasten with same fasteners and continue until other end of opening. **\*\*Note: Keep birdscreen as tight as possible to avoid wrinkles.**

If inside wind rope is being installed use small screw eye for both top and bottom. Spacing of inside screw eyes should be opposite those on page 6. The inside top screw eye should line up underneath each pulley and spaced as per above. Screw eyes are to be mounted on underside of header and on top of bottom board.

**\*\*Note: It is recommended that the rope be installed in approximately 50' sections. Tie off rope at a bottom screw eye and start next 50' length on same screw eye. (This will allow you to more easily tighten and repair wind rope if necessary)**

Once birdscreen is covering the full opening, you can now install top and bottom boards which will sandwich the birdscreen and help hold it in place.

## Wind Rope Installation

To install wind ropes, attach one end of rope to first top screw eye by tying a knot. Thread rope down through first bottom screw eye, then back up to next top screw eye. Continue in this zig-zag fashion to end of section. **\*\*Note: It is recommended that the rope be installed in approximately 50' sections. Tie off rope at a bottom screw eye and start next 50' length on same screw eye. (This will allow you to more easily tighten and repair wind rope if necessary)**

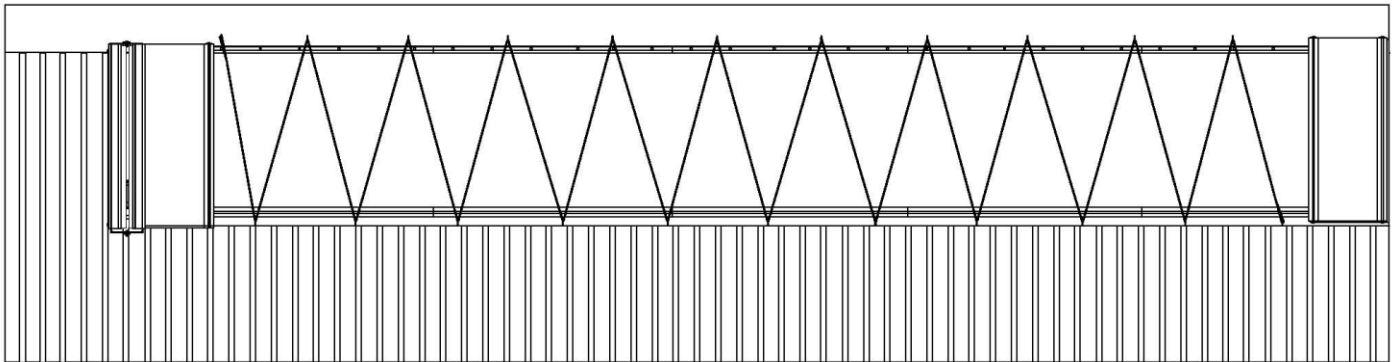

To complete curtain installation, you can now install the outside end pockets (See page 8) and connect bottom tube to drive unit (See page 10).

# Wind Pipe Installation

If curtain system is to have both inside and outside wind pipes, install inside wind pipe after aluminum curtain track installation on page 6. If system is to have outside wind pipes only, they should be installed as the last step of the overall installation.

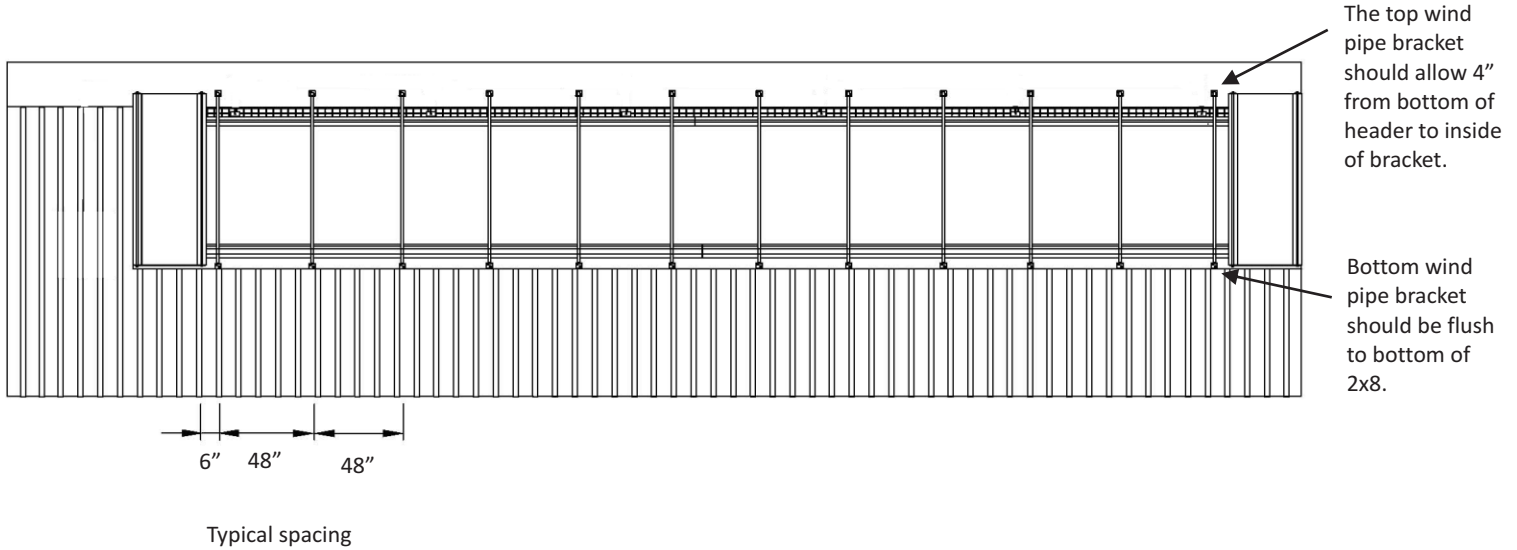

# Wind Pipe Installation

This illustrates a curtain system with wind pipes inside and outside.

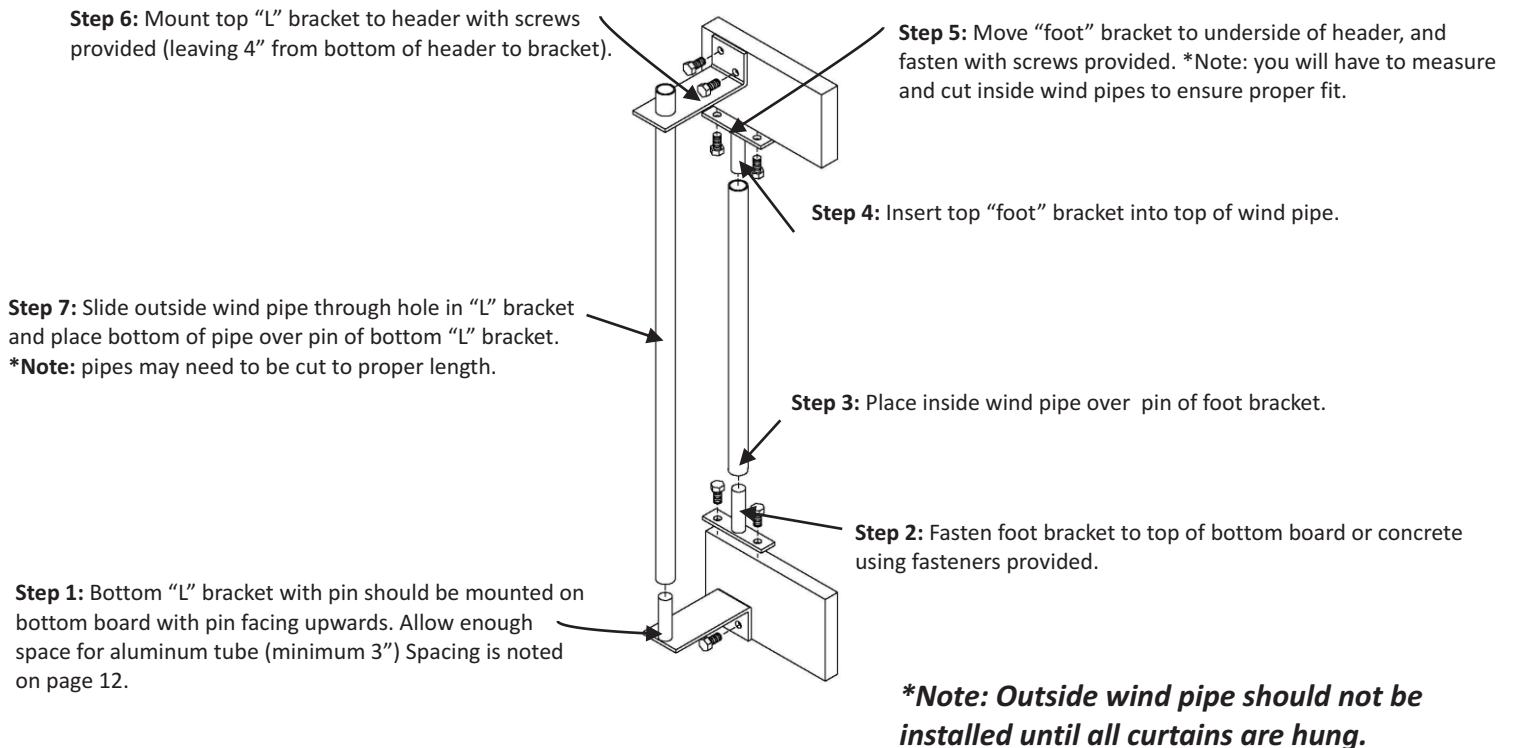

# Wind Pipe Installation (cont'd)

This illustrates a curtain system with wind pipes on outside only.

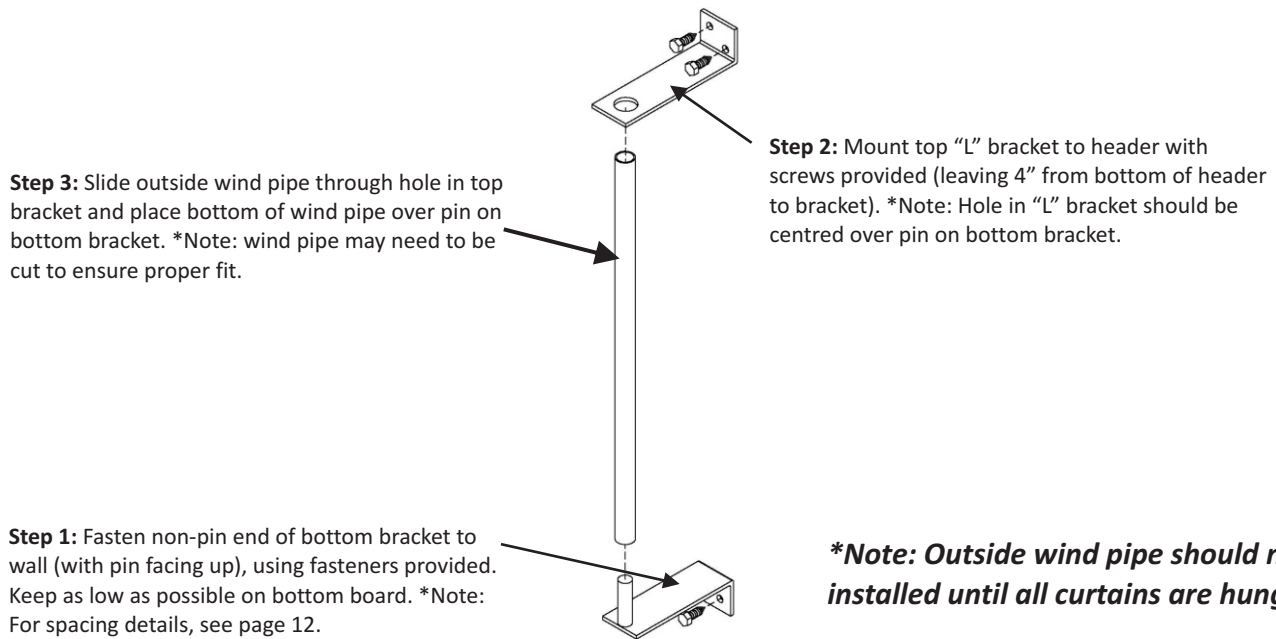

---

# Wind Pipe Installation (cont'd)

This illustrates a split curtain system with inside and outside wind pipes.

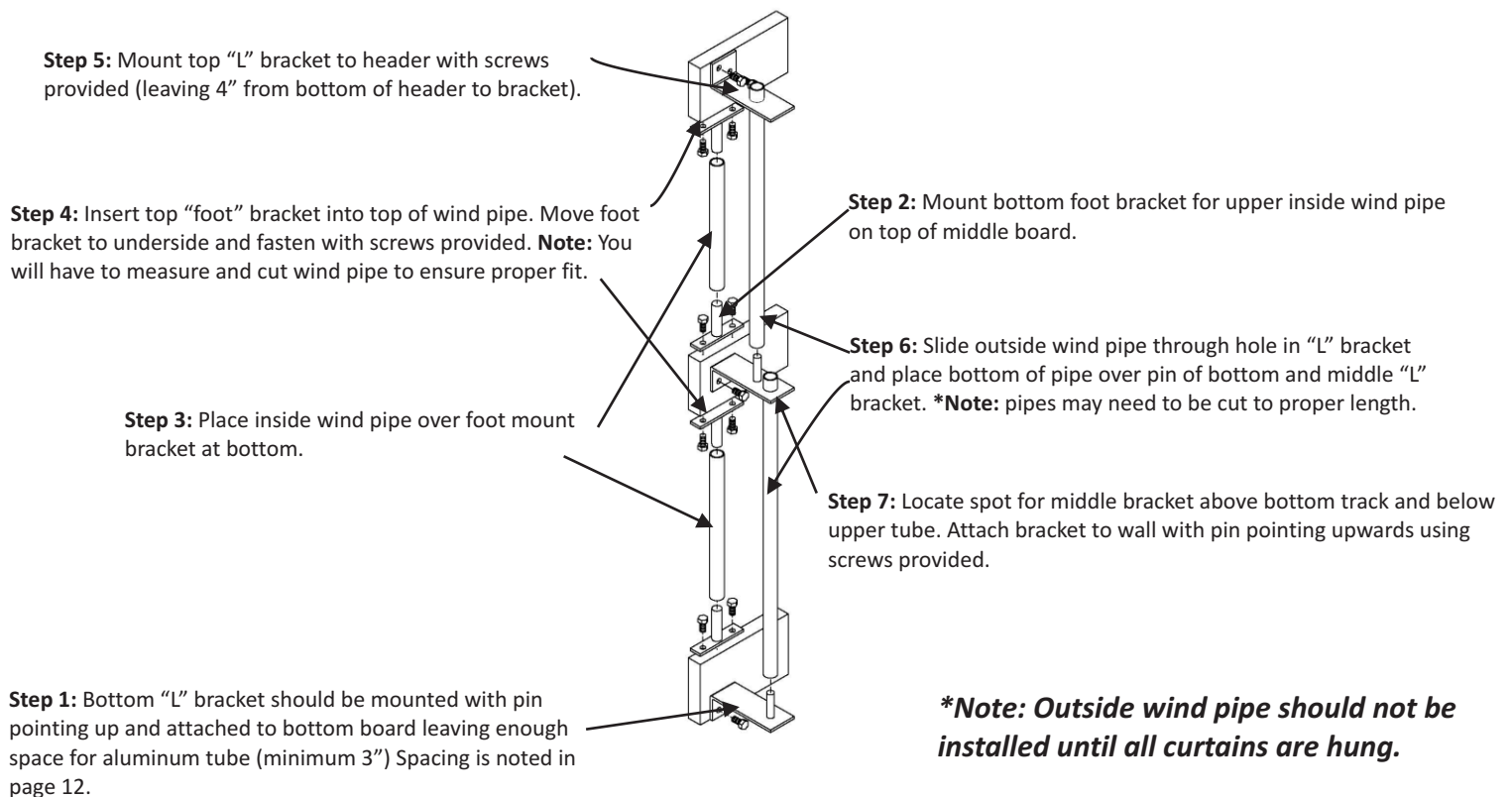

# Limit Switch System

PHOENIX PH 30/14  
(110V AC)

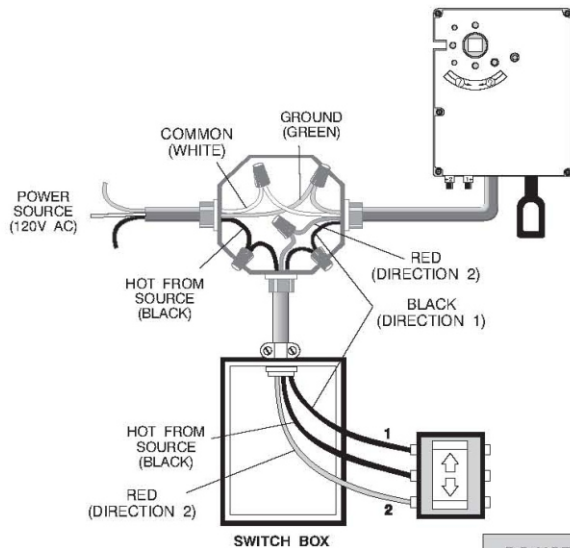

PHOENIX PH 50/12  
(220V AC)

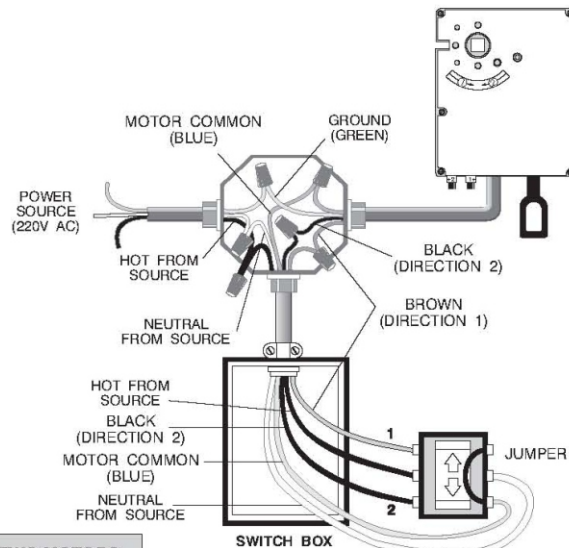

DO NOT WIRE TWO MOTORS TO ONE SINGLE POLE SWITCH (DO NOT WIRE IN PARALLEL)

ALL WIRING MUST BE IN ACCORDANCE WITH N.E.C. AND LOCAL CODES

**MOTOR WIRING COLOR CODE**

PH 30/14 110 VAC	CODE
BLACK	1:DIRECTION
RED	2:DIRECTION
WHITE	COMMON
GREEN	GROUND

**MOTOR WIRING COLOR CODE**

PH 50/12 220 VAC	CODE
BROWN	1:DIRECTION
BLACK	2:DIRECTION
BLUE	COMMON
GREEN	GROUND

## LIMIT SWITCH SETTING

**1. CHECK TO ENSURE THAT YOUR AWNING (or other window covering) IS MOVING IN THE RIGHT DIRECTION.**

After wiring the Phoenix motor, turn the power on to ensure that the switch is operating properly.

If not,

turn the power off, and simply reverse the black and red (or brown and black) motor leads connected to the switch.

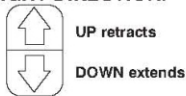

**2. SETTING THE LIMIT SWITCHES.**

-Check the arrow directions near the hollow square drive shaft.  
-The UP and DOWN motor limits are set by the two socket screws located near the manual override hook. Please use for this purpose the Allen wrench included with the motor.

**Setting the "up" position**

- Press the switch in "up" position.
- If the system stops before its Up limit, turn the UP screw to "+" until necessary.
- If the system does not stop before its Up limit, press the switch in "DOWN" direction and turn the UP screw to "-". Repeat this until correct setting is realized.

**Setting the "DOWN" position**

- Press the switch in "DOWN" direction.
- If the system stops before its Down limit, turn the "DOWN" screw to "+".
- If not, press the switch in "UP" direction and turn the DOWN screw to "-". Repeat this until correct setting is realized.

- Screw 1 adjusts direction 1
- Screw 2 adjusts direction 2

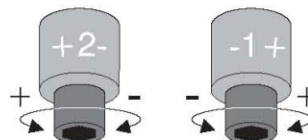

## Finishing Tips and Touches

- 1) It is very critical that the curtain material be “stretched” after it is installed into the top and bottom aluminum tubes. This can be done by fastening the rope and curtain material to the aluminum tube and track, using self tapping screws. Then from the opposite end, pull curtain (not rope) at both top and bottom until all “puckers” have been removed. This will help to avoid “bowing” in the aluminum pipe or creasing of curtain material when curtain system is rolling.
- 2) Make sure that when the curtain is fully closed, there is no curtain left wrapped onto the bottom tube. This will ensure that no debris gets left in the curtain to cause premature wear and/or uneven rolling of curtain material.
- 3) Ensure end pockets are proper distance away from wall after installation is complete. They should allow curtain to roll and have some movement in and out from wall, but not allow excessive movement that might be caused by strong winds permitting excessive air leakage.

### **WARRANTY POLICY**

Faromor Ltd. Warranty Policy covers all parts manufactured and supplied by Faromor. Warranty starts from date of initial installation of product and lasts one (1) year.

Faromor will also give full warranty on any installation labour we provide for a period of up to one (1) year from date of installation.

All digital thermostats have a two (2) year full warranty.

## CURTAIN SYSTEMS SAFETY PRECAUTIONS

**NOTE: ALL INSTALLATION OF ELECTRICAL CONTROLS SHOULD BE DONE BY A QUALIFIED ELECTRICIAN.**

### General Operation

- Curtains should only be operated when the owner or other responsible persons are in the facility.
- Unauthorized persons or small children should not be near or have access to the outside or inside automatic/manual drive units as they may result in injury. Do not attempt to stop any automatic drive unit by hand while it is in operation.
- Do not attempt to adjust cables or pulleys while system is in operation.
- When making adjustments to automatic drive units, ensure that the override switch is in the “off” position so that the curtain cannot start while any work is being completed.

### Protective Covering

- Ensure that all drive units (manual or automatic) have the covers installed where applicable.
- Electrical motors mounted on outside of building should be covered to prevent damage.

## CURTAIN SYSTEMS MAINTENANCE

### RAW/BRU/STD/STDS

- All cables (main and pull-ups) should be checked on a monthly basis to ensure proper operation. Over time, some cables may stretch causing uneven pull up of curtain system. Where necessary, loosen cable clamp, pull cable tight and re-fasten clamp when curtain is level.
- Ensure all cable clamps are tightly secured so it does not result in drop cables coming loose.
- Ensure curtains remain pulled tight from one end to the other. If curtain seems to be bunching or creasing, curtain may need to be tightened.
- Check all pulleys for excess wear on wheels that may cause cable to get caught.
- Periodically check over aluminum tubes to ensure they are connected tightly.
- Check end pockets to ensure all nuts and bolts are tightly secured.
- Tighten windropes as necessary to make sure there is no slack.
- For bottom roll-up systems, ensure aluminum track is clear of any debris and that gearbox wheels are turning smoothly.

### PRC

- Ensure all mounting brackets are secured tightly to wall and to end of aluminum tube.
- Periodically check that center support rollers are rolling properly and not seized.
- If applicable, ensure valance does not get caught in roller tube.
- Check for wear on sidewall seals periodically if heavy cow traffic is an issue.

**NOTE: FOR ANY SERVICE ON THERMOSTATS OR AUTOMATIC DRIVE UNITS, PLEASE CONTACT A FAROMOR SERVICE REPRESENTATIVE FOR ASSISTANCE. FOR ADJUSTMENT OF LIMIT SWITCHES SEE INSTALLATION MANUALS – ELECTRICAL SECTION.**

**General Cleaning:**

- Use mild soap or detergents for cleaning any of our Faromor products – do not use solvents or aggressive cleaning agents.
- High pressure washers can be used on all products but maintain a minimum distance from product of approximately 1m so as not to put too much pressure on the material – especially fabric curtains.
- Ensure rolling curtains are in the fully closed position when washing so that excess water does not get caught in the rolls of the fabric – allow the water to run completely off the curtains.
- Avoid direct pressure on any curtain area that has an existing hole or ClearVu panel that has an existing crack – the added water pressure may cause more damage at those locations.
- **FOR DRIVE UNITS** – it is recommended to do a simple hand cleaning of the units with warm water and avoid excess water around the motor, wiring or vent plugs so no water will enter the gears or damage the wiring – this will cause premature failure.

**NOTE: DO NOT USE HIGH PRESSURE WASHERS OR WATER OF ANY KIND TO CLEAN DRIVE UNITS OR THERMOSTATS – THIS WILL DAMAGE THE UNITS.**