

1

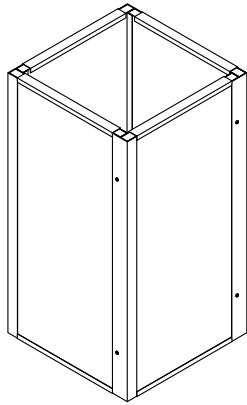

3

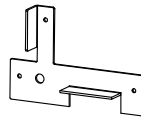

7



4



2

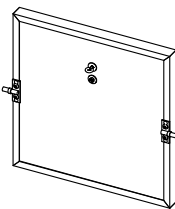

5

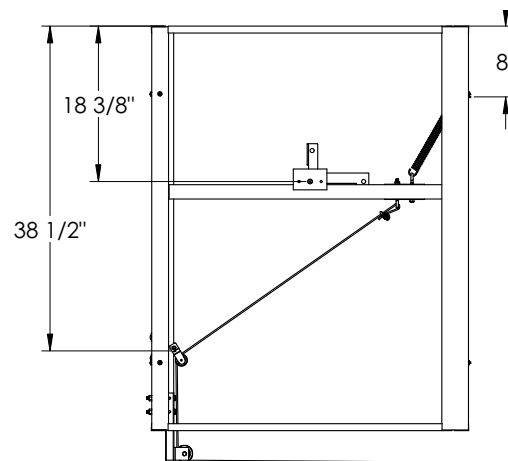
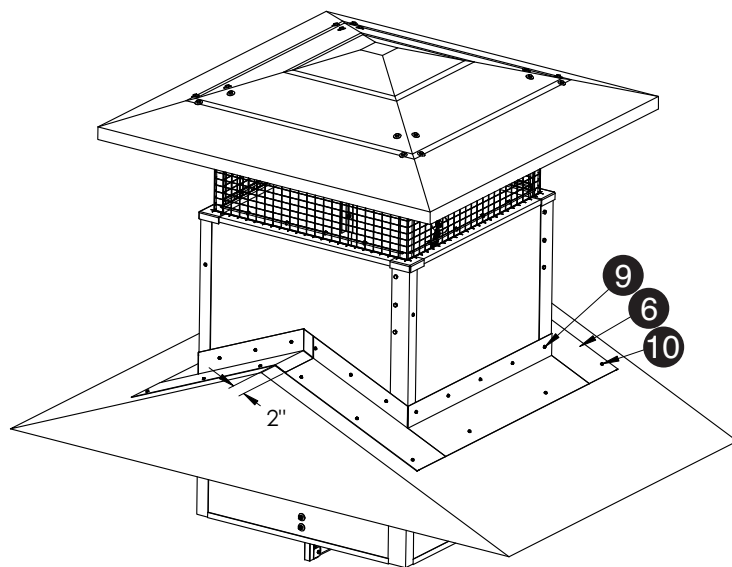
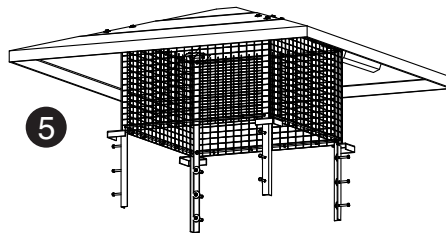

ITEM NO.	PART NUMBER	DESCRIPTION
1	05-200-16	36" X 36" CHIMNEY SECTION
2	05-201-16	FRP CHIMNEY DAMPER FOR 36" X 36"
3	05-202-15	FRP CHIMNEY DAMPER STOP PLATE
4	05-203-15	PIVOT PLATE 2" X 4"
5	05-210-16	CHIMNEY CAP & HARDWARE 36"
6	05-220-16	CHIMNEY FLASHING FOR 36" X 36" FRP
7	08-140-15	FRP CHIMNEY HARDWARE PACKAGE
8 (NOT SHOWN)	09-200-10-18	TY-RAP 7.5 BLACK
9	WGRIP10X1WW	WOODGRIP #10 X 1" W/W
10	WGRIP10X2WW	WOODGRIP #10 X 2" W/W

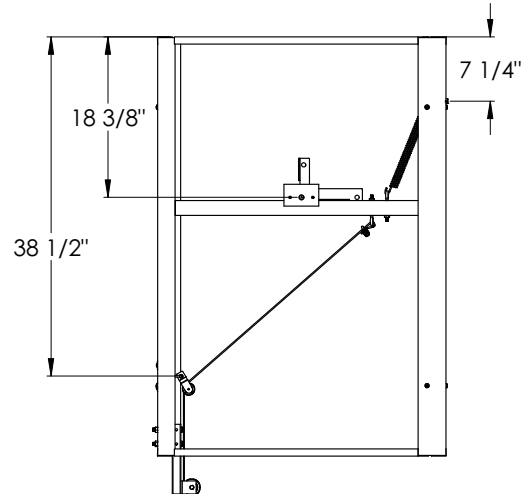
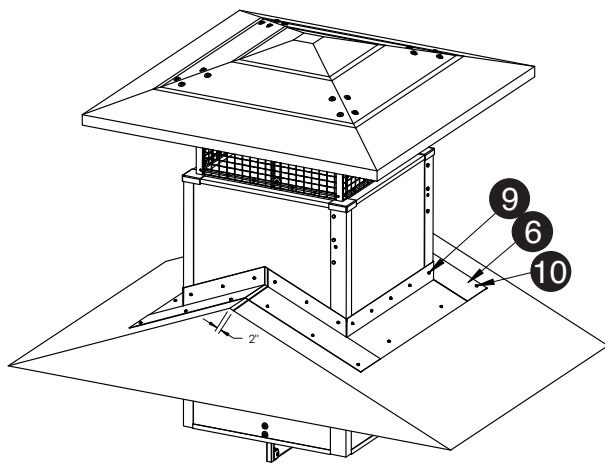
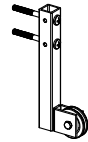
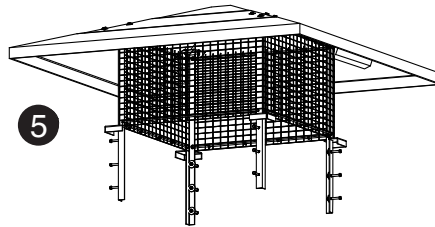
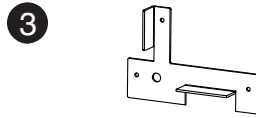
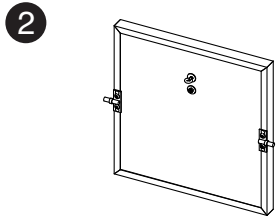
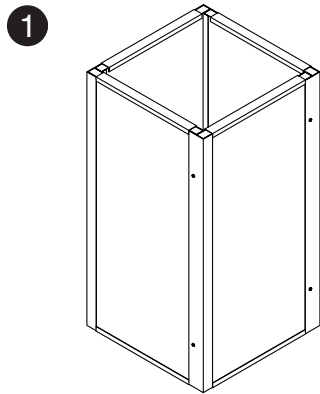

ITEM NO.	PART NUMBER	DESCRIPTION
1	05-200-15	30" X 30" FRP CHIMNEY SECTION
2	05-201-15	FRP 30" X 30" CHIMNEY DAMPER
3	05-202-15	FRP CHIMNEY DAMPER STOP PLATE
4	05-203-15	PIVOT PLATE 2" X 4"
5	05-210-15	CHIMNEY CAP & HARDWARE 30"
6	05-220-15	CHIMNEY FLASHING FOR 30" X 30" FRP
7	08-140-15	FRP CHIMNEY HARDWARE PACKAGE
8 (NOT SHOWN)	09-200-10-18	TY-RAP 7.5 BLACK
9	WGRIP10X1WW	WOODGRIP #10 X 1" W/W
10	WGRIP10X2WW	WOODGRIP #10 X 2" W/W

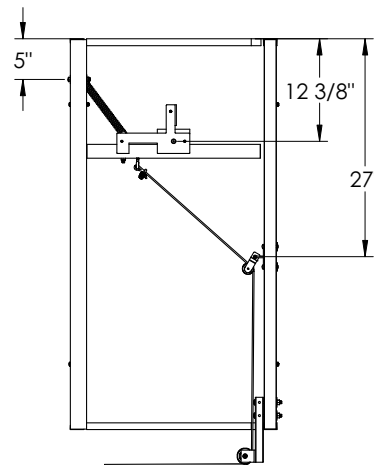
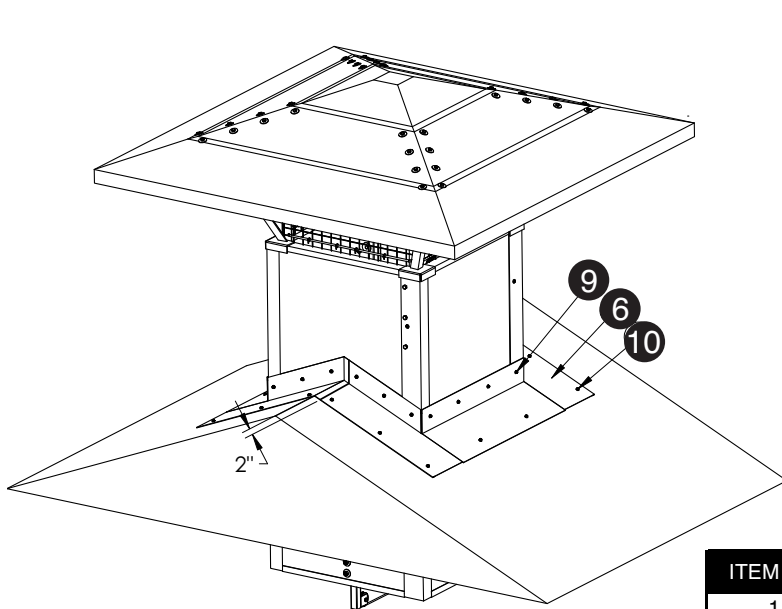
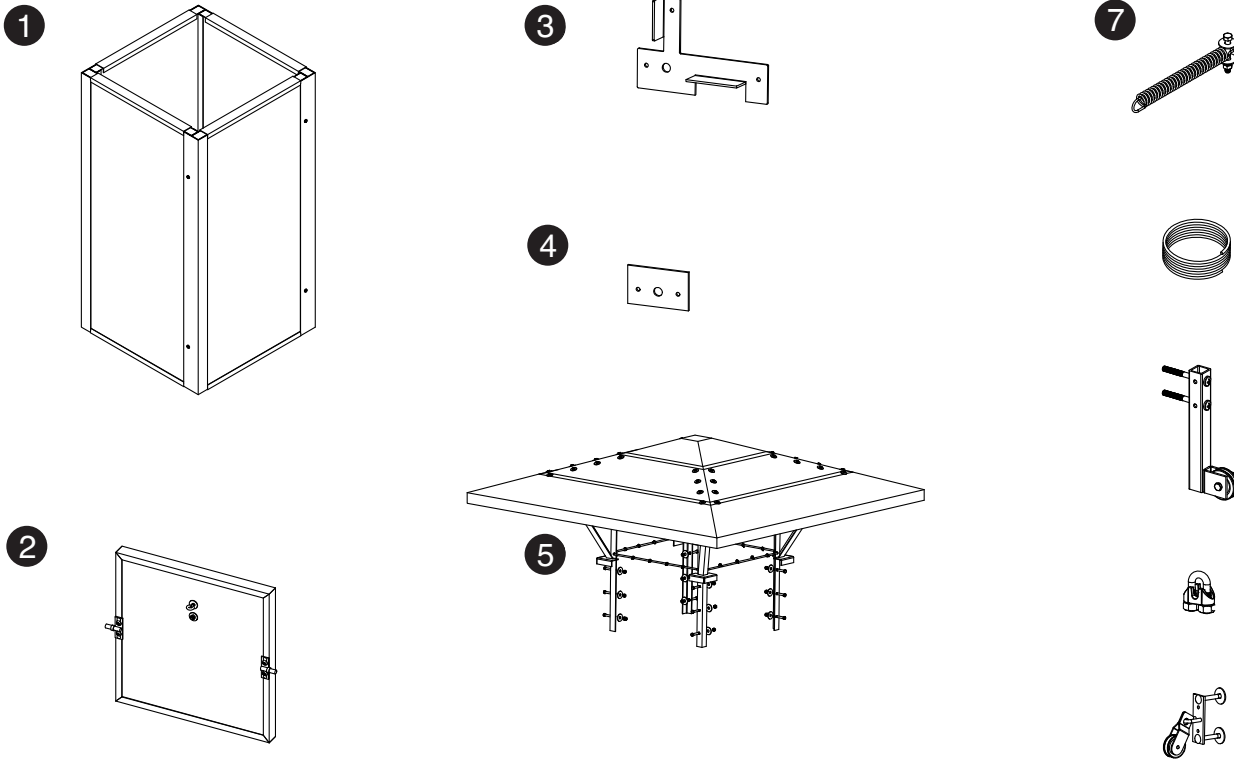

ITEM NO.	PART NUMBER	DESCRIPTION
1	05-200-17	24" X 24" CHIMNEY 4' SECTION
2	05-201-17	24" FRP CHIMNEY DAMPER
3	05-202-15	FRP CHIMNEY DAMPER STOP PLATE
4	05-203-15	PIVOT PLATE 2" X 4"
5	05-210-17	CHIMNEY CAP & HARDWARE 24"
6	05-220-17	24" FRP CHIMNEY FLASHING
7	08-140-15	FRP CHIMNEY HARDWARE PACKAGE
8 (NOT SHOWN)	09-200-10-18	TY-RAP 7.5 BLACK
9	WGRIP10X1WW	WOODGRIP #10 X 1" W/W
10	WGRIP10X2WW	WOODGRIP #10 X 2" W/W

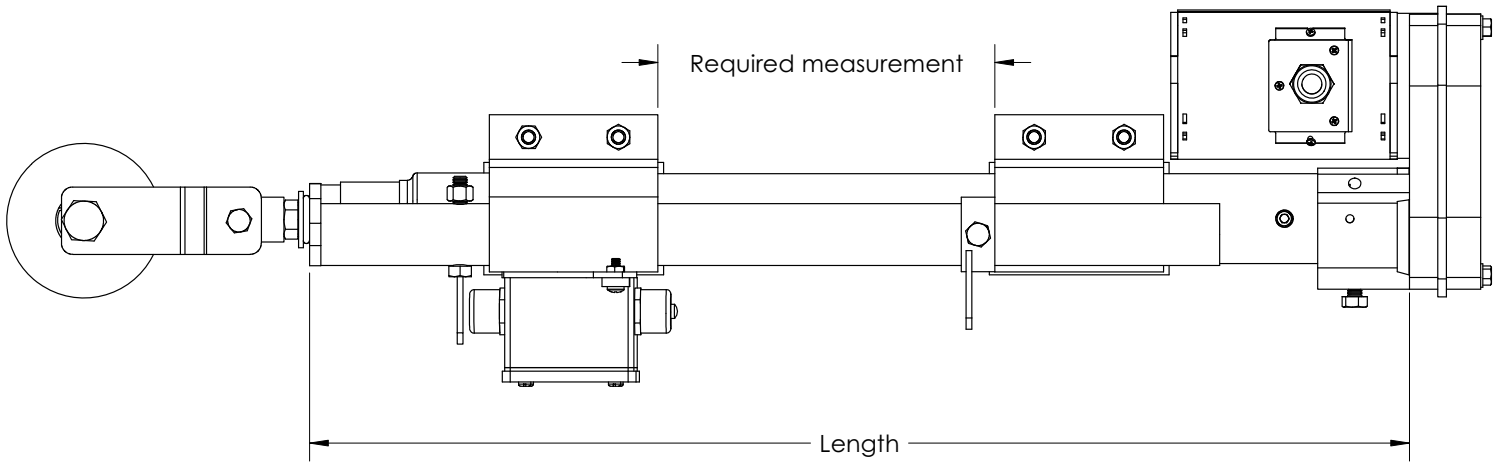

PART NUMBER	STROKE LENGTH	LENGTH	REQUIRED MEARSUREMENT
09-111-36	09-110-36	36"	46"
09-111-48	09-110-48	48"	58"

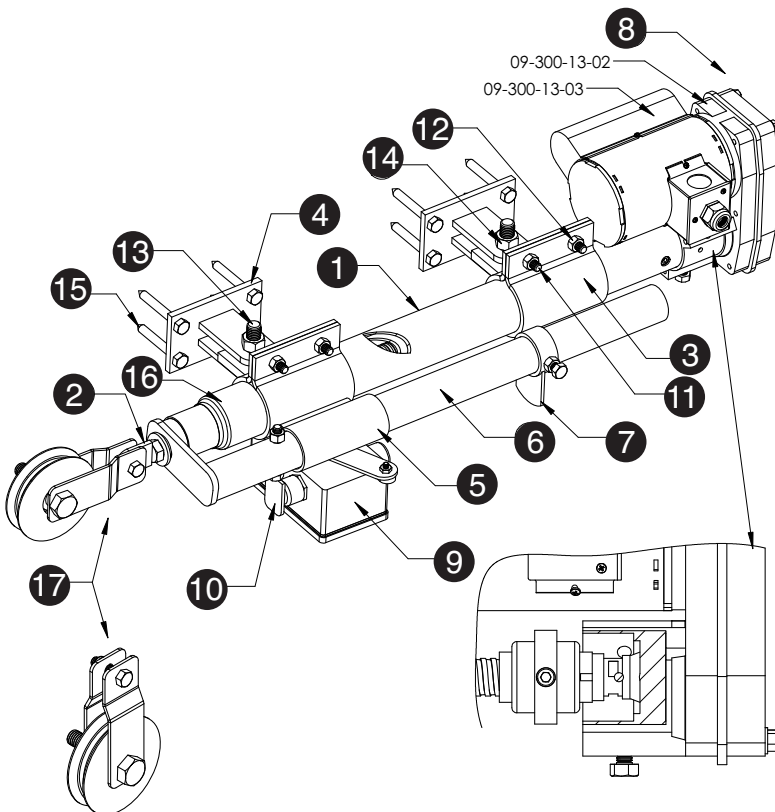

110V LINEAR ACTUATOR

09-110- (36, 48)

ITEM	PART NUMBER	DESCRIPTION
1	09-202-36	36" S.S. POST WITH SEAL
	09-202-48	48" S.S. POST WITH SEAL
2	09-203-13	ACTUATOR NOSE PIECE
3	09-210-13	ACTUATOR MOUNT CLAMP
4	09-220-13	ACTUATOR WALL MOUNT BRACKET
5	09-230-18	LIMIT SWITCH MOUNT & GUIDE
6	09-250-36	FOLLOWER PIPE
	09-250-48	
7	09-251-13	ADJUSTABLE FLAG COLLARS
8	09-300-13	110V POWERHEAD
	09-300-13-02	POWERHEAD GEAR CASE ONLY
	09-300-13-03	POWERHEAD MOTOR ONLY
9	09-340-13	110V LIMIT SWITCH ASSEMBLY
10	09-351-13	FLAG FOR ACTUATOR - STATIONARY
11	BZHCS5162G2	5/16" - 18 X 2" HEX CAP SCREW GR 2
12	NZHN516GR2	5/16" HEX FIN FULL NUT
13	BSHCS122	1/2" - 13 X 2" HEX CAP SCREW SS
14	NSHN12FF	1/2" - 13 HEX NUT FIN FULL SS
15	BZHLB516212	5/16" - 2 1/2" HEX LAG BOLT ZINC
16	09-202-13-21	SEAL KIT WIPER 2"
110V LINEAR ACTUATOR W/DOUBLE PULL		
90-111- (13, 18, 24, 36 48, 60)		
	09-110	110V ACTUATOR
17	08-330-13	3 1/2" PULLEY/W SS HARNESS

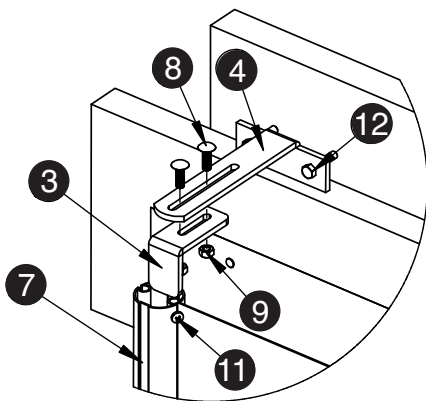
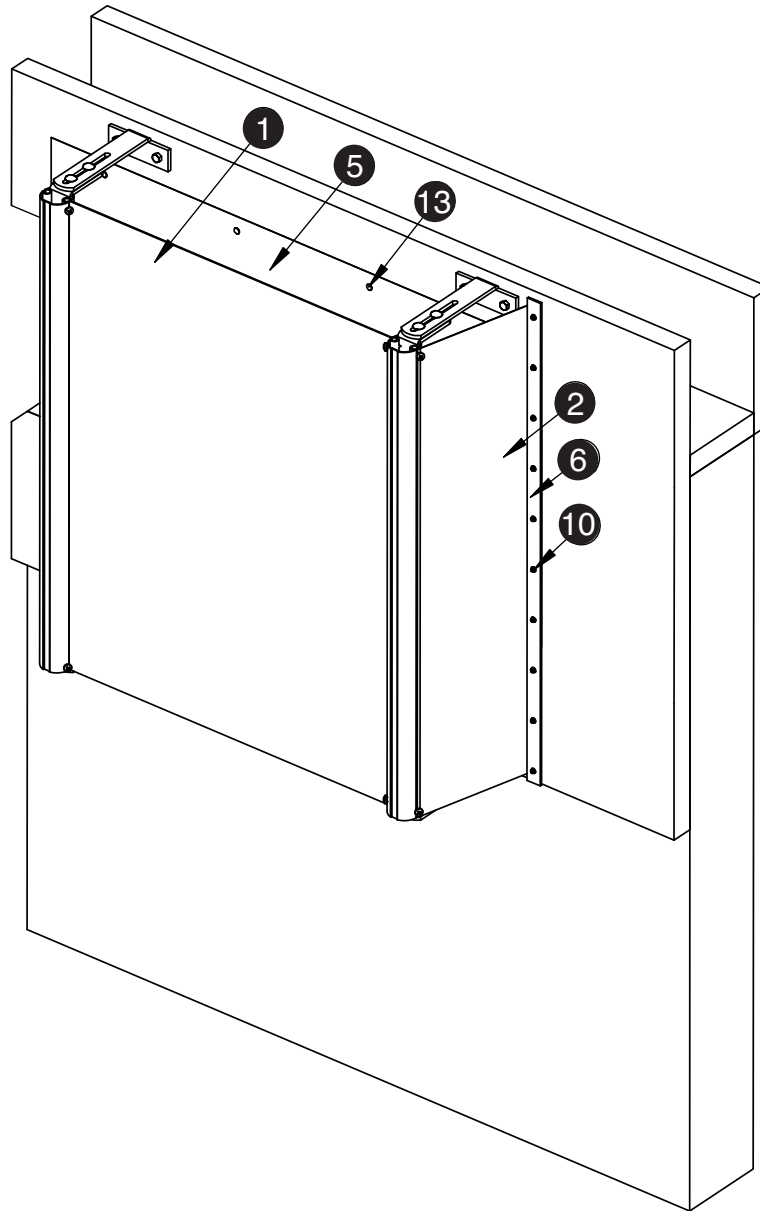

ITEM NO.	PART NUMBER	DESCRIPTION
1	04-143-03	FABRENE CURTAIN 3' HIGH/W DOUBLE ROPE
2	04-144-01	FABRENE CURTAIN 1' HIGH/W SINGLE ROPE
3	04-241-03-03	END POCKET TUBE HOLDER BRACKET
4	04-241-03-04	"NEW STYLE" END POCKET BRACKET W/SLOT
5	04-243-03 TO 04-243-12	INSIDE END POCKET (6' WIDE X CURTIAN HEIGHT + 1')
6	05-200-01-06	NAILER STRIP 1/8" X 1" X 8' PVC
7	08-230-01-09	2" ALUMINUM TUBE
8	BSCB5161	5/16" X 1" SS CARRIAGE BOLT
9	NSRL516NENM	5/16" X 18 RINGLOCK NE/NM SS
10	WGRIP10X1WW	WOODGRIP #10 X 1" W/W
11	SSMS81PST	8 X 1 PAN SACK TEK SCREW SS
12	BZHLB5162	5/16" X 2" ZINC HEX LAG BOLT
13	--	1 1/4" ROOFING NAIL

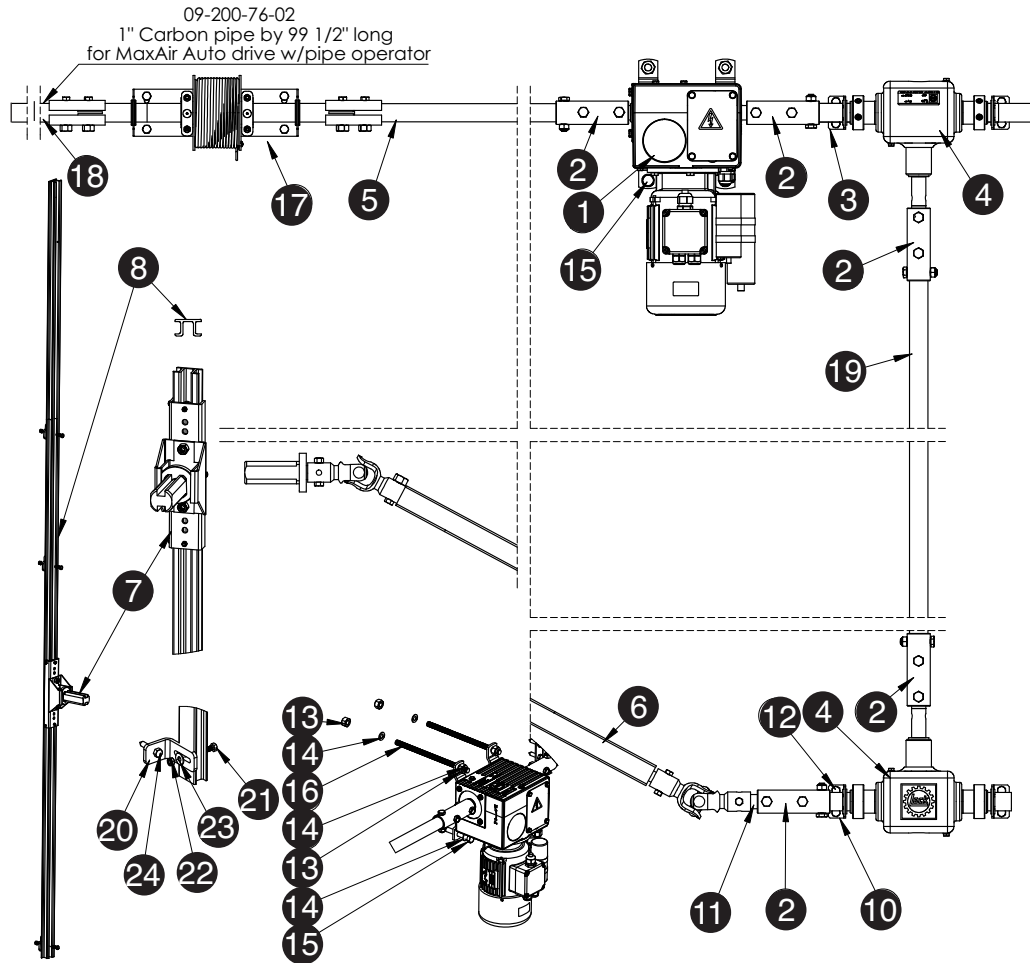

ITEM NO.	PART NUMBER	DESCRIPTION
1	LDEWA12.4503	POWER DRIVE 250NM 3.8RPM WE06 240V 60HZ END20.40 A60 UL+CSA
2	LDBKS45.0634	BUSH COUPLING WE06 FOR TUBE 1" + SCREWS
3	LDELD12.9807	DRIVE TUBE BEARER, ANGLED LL = 70MM STEEL BRONZE INSERT, ANGLED
4	LDKGO32.1115	DEFLECTION GEAR UNIT 150NM 1:1 WE73 WITH LOCKING RING
5	09-200-76-01	1" CARBON PIPE BY 55" LONG FOR MAX AIR AUTO DRIVE W/PIPE OPERATION
6	LDGKT06.2347	TELESCOPIC COUPLING 06 HL = 2.30 M >TUBE INSIDE 47MM
7	LDWRZ10.4021	END GUIDE INCL. WRZ10.0120
8	LDWRZ01.0130	GUIDING PROFILE FOR 1 ROLLER CARRIAGE L = 3.00M
9	SZWS14112TA (NOT SHOWN)	14 X 1 1/2" THRD FRM SOCK A PAN
10	LDELD12.9809	DRIVE TUBE BEARER, ANGLED LL = 90MM STEEL BRONZE INSERT, ANGLED
11	LDGKA06.0680	ADAPTER WE06 X 80MM
12	BZHLB142	1/4" X 2 HEX LAG SCREW ZINC
	09-200-76-10	LD MOUNTING KIT
13	NZHN12	1/2 -13 HEZ NUT GR5
14	WZPQ12	1/2 ZINC WASHER
15	BZHCS12312	1/2 -13 X 3 1/2 HEX CAP LAG SCREW ZINC
16	TR1236C	1/2 -13 THREADED ROD COARSE ZINC (PER FOOT)
17	08-130-60	CABLE DRUM KIT FOR MAX AIR CURTAIN (INCL. CABLE & LIFT TAB)
18	09-200-76-02	1" CARBON PIPE BY 99 1/2" LONG FOR MAX AIR AUTO DRIVE W/PIPE OPERATION
19	09-200-76-04	1" CARBON PIPE BY 120" LONG FOR MAX AIR AUTO DRIVE W/PIPE OPERATION
20	04-241-03-03	END POCKET TUBE HOLDER BRACKET
21	BSHCS5161	5/16"-18 X 1" HEX CAP SCREW SS
22	NSHN516FF	5/16"-18 HEX NUT FIN FULL SS
23	WSFW516	5/16" FLAT WASHER SS
24	BZHLB382	3/8" X 2" ZINC HEX LAG BOLT

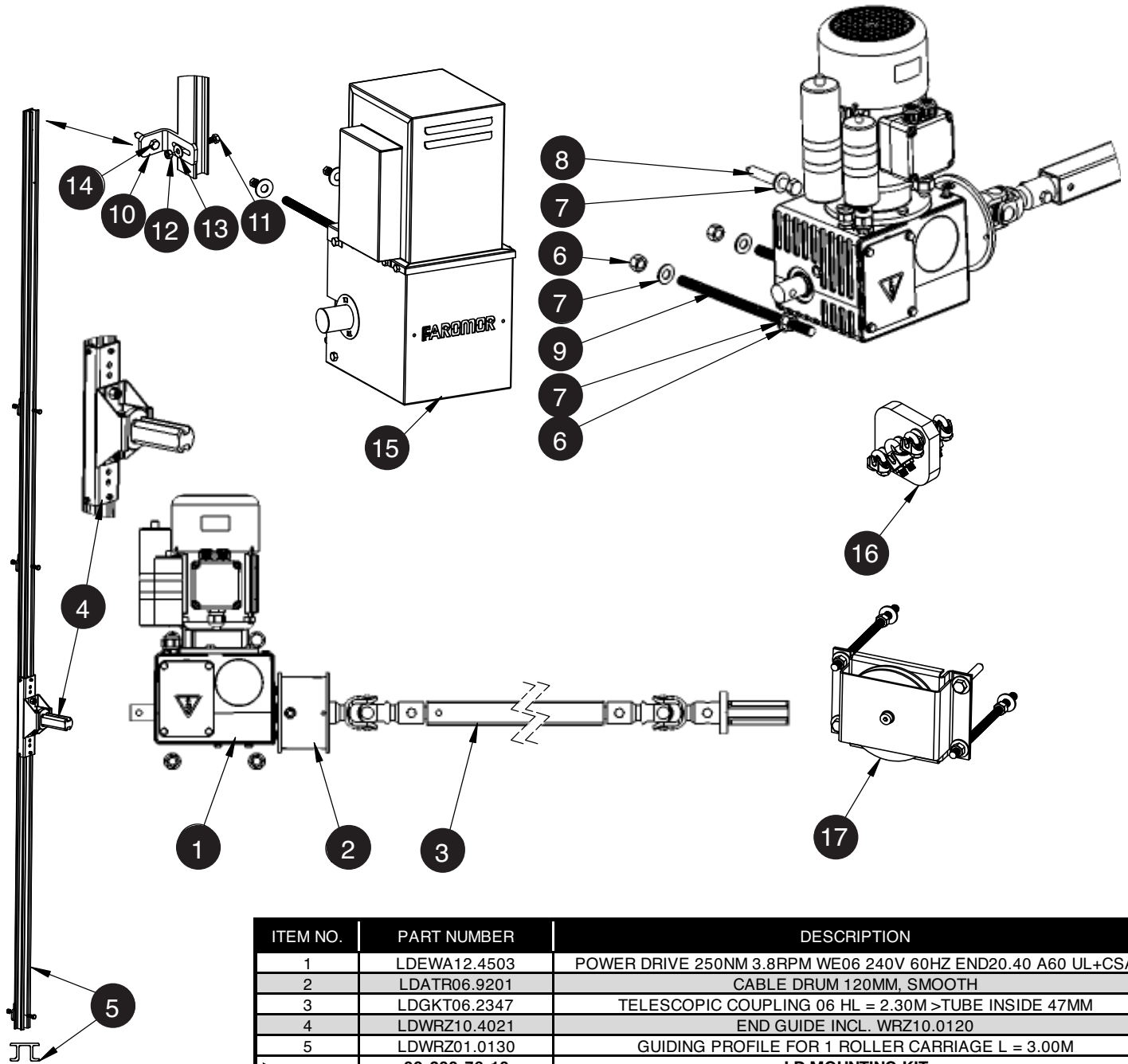

NOTE: BOLD=ASSEMBLY

ITEM NO.	PART NUMBER	DESCRIPTION
1	LDEWA12.4503	POWER DRIVE 250NM 3.8RPM WE06 240V 60HZ END20.40 A60 UL+CSA
2	LDATR06.9201	CABLE DRUM 120MM, SMOOTH
3	LDGKT06.2347	TELESCOPIC COUPLING 06 HL = 2.30M >TUBE INSIDE 47MM
4	LDWRZ10.4021	END GUIDE INCL. WRZ10.0120
5	LDWRZ01.0130	GUIDING PROFILE FOR 1 ROLLER CARRIAGE L = 3.00M
	09-200-76-10	LD MOUNTING KIT
6	NZHN12	1/2 -13 HEX NUT GR5
7	WZPQ12	1/2 ZINC WASHER
8	BZHCS12312	1/2-13 X 3 1/2" HEX CAP LAG SCREW ZINC
9	TR1236C	1/2-13 THREADED ROD COARSE ZINC (PER FOOT)
10	04-241-03-03	END POCKET TUBE HOLDER BRACKET
11	BSHCS5161	5/16"-18 X 1" HEX CAP SCREW SS
12	NSHN516FF	5/16"-18 HEX NUT FIN FULL SS
13	WSFW516	5/16" FLAT WASHER SS
14	BZHLB382	3/8" X 2" ZINC HEX LAG BOLT
15	09-208-58	LD N.A. RAW SS COVER
16	08-131-50	CABLE ANTI-TWIST PLATE ASSEMBLY
17	08-131-20	FLUSH MOUNT PULLEY 6"

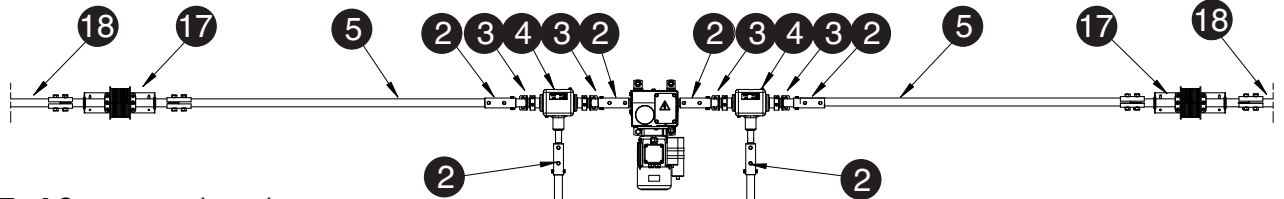

Note: Item 17+18 are not part of 09-101-76

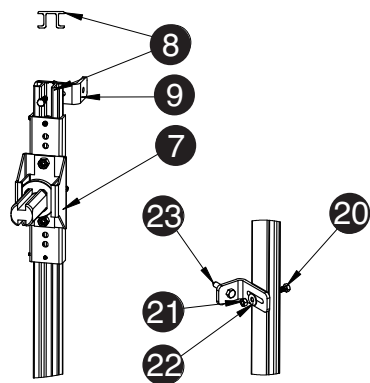
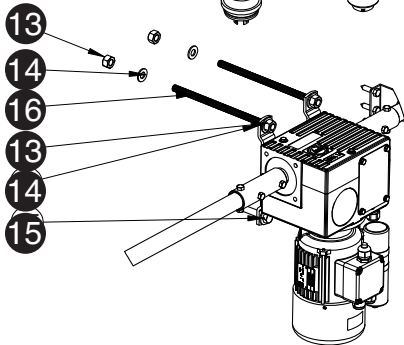
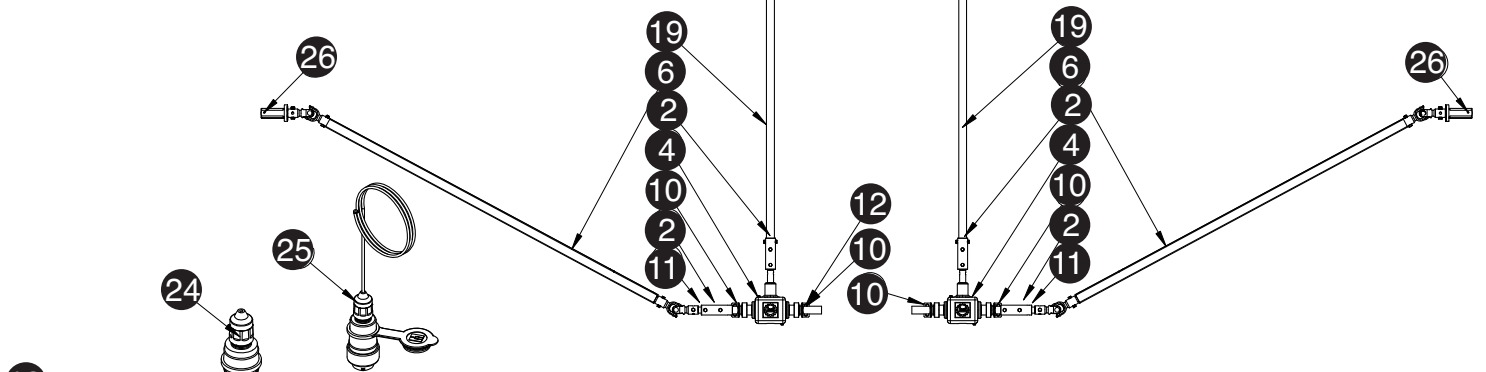

NOTE: BOLD = ASSEMBLY

ITEM NO.	PART NUMBER	DESCRIPTION
1	LDEWA12.2503	POWER DRIVE 450NM 3.8RPM WE06 240V 60HZ END20.40 A60 UL+CSA
2	LDBKS45.0634	BUSH COUPLING WE06 FOR TUBE 1" + SCREWS
3	LDELD12.9807	DRIVE TUBE BEARER, ANGLED LL = 70MM STEEL BRONZE INSERT, ANGLED
4	LDKGO32.1115	DEFLECTION GEAR UNIT 150NM 1:1 WE73 WITH LOCKING RING
5	09-200-76-01	1" CARBON PIPE BY 55" LONG FOR MAX AIR AUTO DRIVE W/PIPE OPERATION
6	LDGKT06.2347	TELESCOPIC COUPLING 06 HL = 2.30 M >TUBE INSIDE 47MM
7	LDWRZ10.4021	END GUIDE INCL. WRZ10.0120
8	LDWRZ01.0130	GUIDING PROFILE FOR 1 ROLLER CARRIAGE L = 3.00M
9	04-241-03-03	END POCKET TUBE HOLDER BRACKET
10	LDELD12.9809	DRIVE TUBE BEARER, ANGLED LL = 90MM STEEL BRONZE INSERT, ANGLED
11	LDGKA06.0680	ADAPTER WE06 X 80MM
12	BZHLB142	1/4" X 2 HEX LAG SCREW ZINC
	09-200-76-10	LD MOUNTING KIT
13	NZHN12	1/2"-13 HEX NUT GR5
14	WZPQ12	1/2" ZINC WASHER
15	BZHCS12312	1/2 -13 X 3 1/2 HEX CAP LAG SCREW ZINC
16	TR1236C	1/2 -13 THREADED ROD COARSE ZINC (PER FOOT)
17	08-130-60	CABLE DRUM KIT FOR MAX AIR CURTAIN (INCL. CABLE & LIFT TAB)
18	09-200-76-02	1" CARBON PIPE BY 99 1/2" LONG FOR MAX AIR AUTO DRIVE W/PIPE OPERATION
19	09-200-76-04	1" CARBON PIPE BY 120" LONG FOR MAX AIR AUTO DRIVE W/PIPE OPERATION
20	BSHCS5161	5/16"-18X1" HEX CAP SCREW SS
21	NSRL516NENM	5/16"-18 RINGLOCK NE/NM SS
22	WSFW516	5/16" FLAT WASHER SS
23	BZHLB382	3/8"X2" ZINC BEX LAG BOLT
24	09-200-76-40	PLUG, MALE END, 20A 125 250V, 26W74
25	09-300-76-01	FEMALE END OF SAFETY POWER CORD (WITH 10' CORD)
26	R31638	3/16" X 3/8" POP RIVET

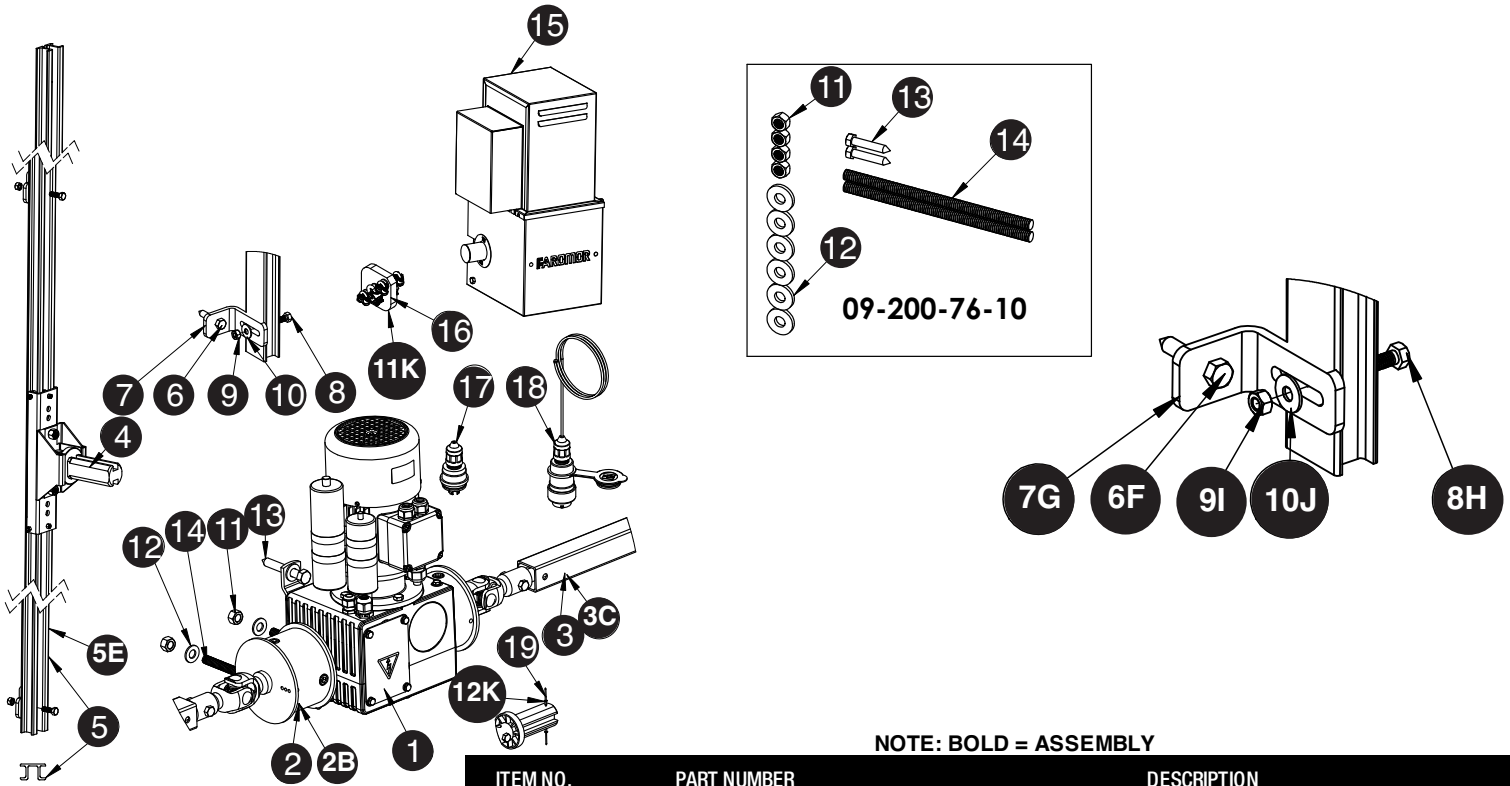

NOTE: BOLD = ASSEMBLY

ITEM NO.	PART NUMBER	DESCRIPTION
1A	09-100-77	MAX AIR AUTO DRIVE W/ CABLE OPERATION
2B	LDATR06.9201	CABLE DRUM 120mm, SMOOTH
3C	LDGKT06.2347	TELESCOPIC COUPLING 06 HL = 2.30 M >TUBE INSIDE 47MM
4D	LWRZ10.4021	END GUIDE INCL. WRZ10.0120
5E	LDWRZ01.0130	GUIDING PROFILE FOR 1 ROLLER CARRIAGE L = 3.00M
6F	BZHLB382	3/8"X2" ZINC HEX LAG BOLT
7G	04-241-03-03	END POCKET TUBE HOLDER BRACKET
8H	BSHCS5161	5/16"-18X1" HEX CAP SCREW SS
9I	NSHN516FF	5/16"-18 HEX NUT FIN FUL SS
10J	WSFW516	5/16" PLATE WASHER SS
11K	08-131-50	CABLE ANTI-TWIST PLATE ASSY
12K	R31638	3/16"X3/8"POP RIVET

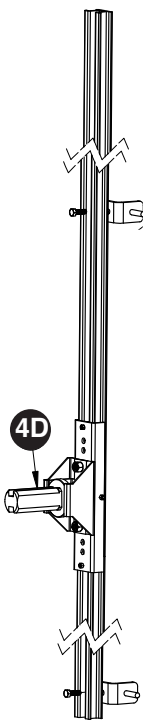

09-100-77 MAX AIR AUTO DRIVE W/ CABLE OPERATION		
1	LDEWA12.2503	POWER DRIVE 250NM 3.8PM WE06 240V 60Hz END20.40
2	LDATR06.9201	CABLE DRUM 120mm, SMOOTH
3	LDGKT06.2347	TELESCOPIC COUPLING 06 HL = 2.30 M >TUBE INSIDE 47MM
4	LWRZ10.4021	END GUIDE INCL. WRZ10.0120
5	LDWRZ01.0130	GUIDING PROFILE FOR 1 ROLLER CARRIAGE L = 3.00M
6	BZHLB382	3/8"X2" ZINC HEX LAG BOLT
7	04-241-03-13	END POCKET TUBE HOLDER BRACKET
8	BSHCS5161	5/16"-18X1" HEX CAP SCREW SS
9	NSHN516FF	5/16"-18 HEX NUT FIN FUL SS
10	WSFW516	5/16" FLAT WASHER SS

09-200-76-10 LD MOUNTING KIT		
11	NZHN12	1/2-13 HEZ NUT GR5
12	WZPQ12	1/2 ZINC WASHER
13	BZHCS12312	1/2-13 X 3/2 HEX CAP LAG SCREW ZINC
14	TR1236C	1/2-13 THREADED ROD COARSE ZINC (PER FOOT)
15	09-208-58	LD N.A. RAW SS COVER COMPLETE
16	08-131-50	CABLE ANTI-TWIST PLATE ASSY
17	09-200-76-40	PLUG, MALE END 20A 125 250V 26W74
18	09-300-76-01	FEMALE END OF SAFETY POWER CORD (WITH 10' CORD)
19	R31638	1/16" X 3/8" POP RIVET

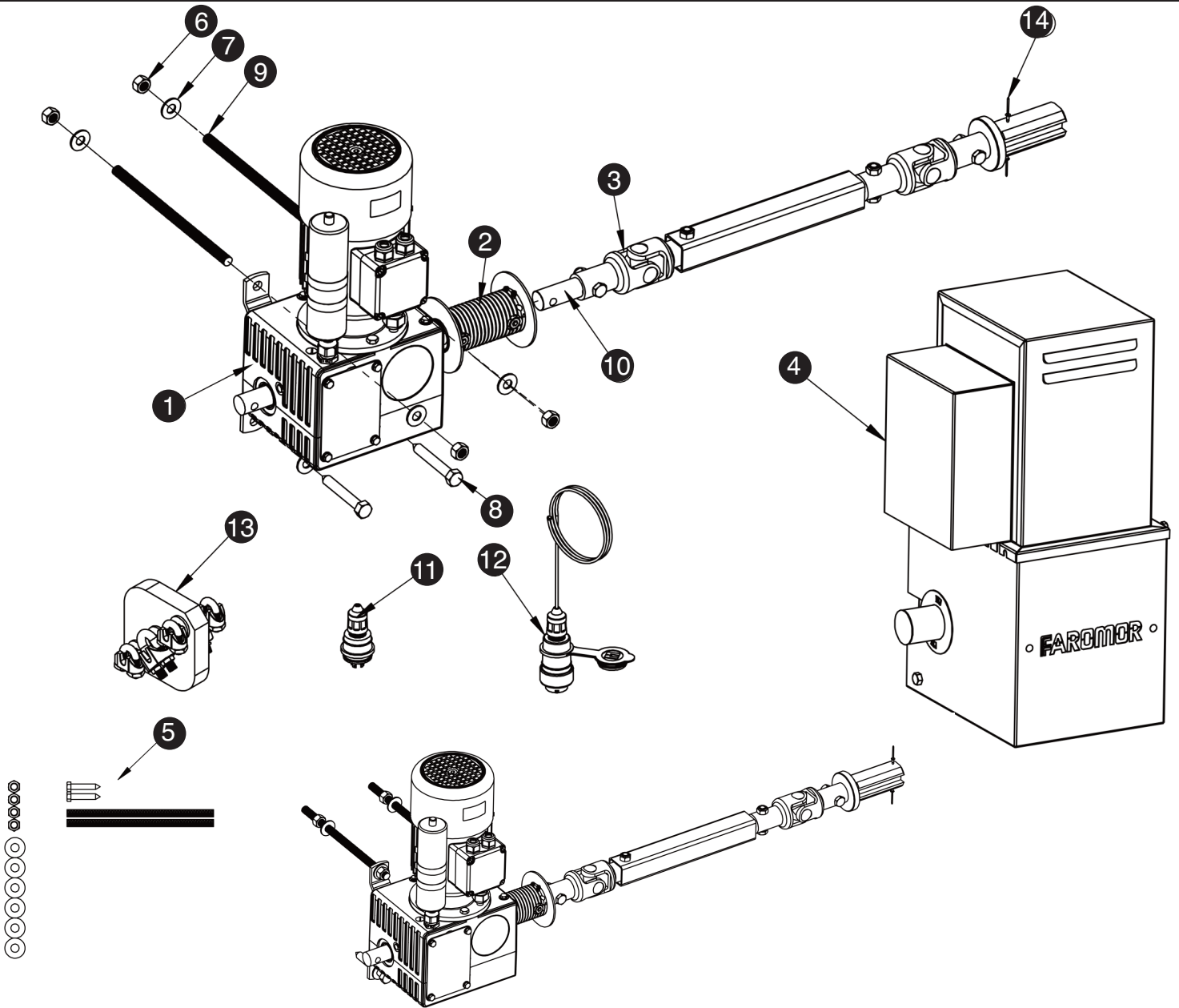

NOTE: BOLD = ASSEMBLY

ITEM NO.	PART NUMBER	DESCRIPTION
1	LDEWA12.2503	POWER DRIVE 250NM 3.8RPM WE06 240V 60HZ END20.40 A60 UL+CSA
2	LDATR 06.5403	CABLE DRUM54MM, GROOVED
3	LDGK 04.0447	TELESCOPIC COUPLING 04 HL=0.40M>47MM
4	09-208-58	LD N.A. RAW SS COVER
5	09-200-76-10	LD MOUNTING KIT
6	NZHN12	1/2"-13 HEX NUT GR5
7	WZPQ12	1/2" ZINC WASHER
8	BZHCS12312	1/2"-13 X 3 1/2" HEX CAP LAG SCREW ZINC
9	TR1236C	1/2"-13 THREADED ROD COARSE ZINC (PER FOOT)
10	LDGKA06.0680	ADAPTER WE06X80MM
11	09-200-76-40	PLUG, MALE END, 20A 125 250V,26W74
12	09-300-76-01	FEMALE END OF SAFETY POWER CORD (WITH 10' CORD)
13	08-131-50	CABLE ANTI-TWIST PLATE ASSEMBLY
14	R31638	3/16"X3/8" POP RIVET

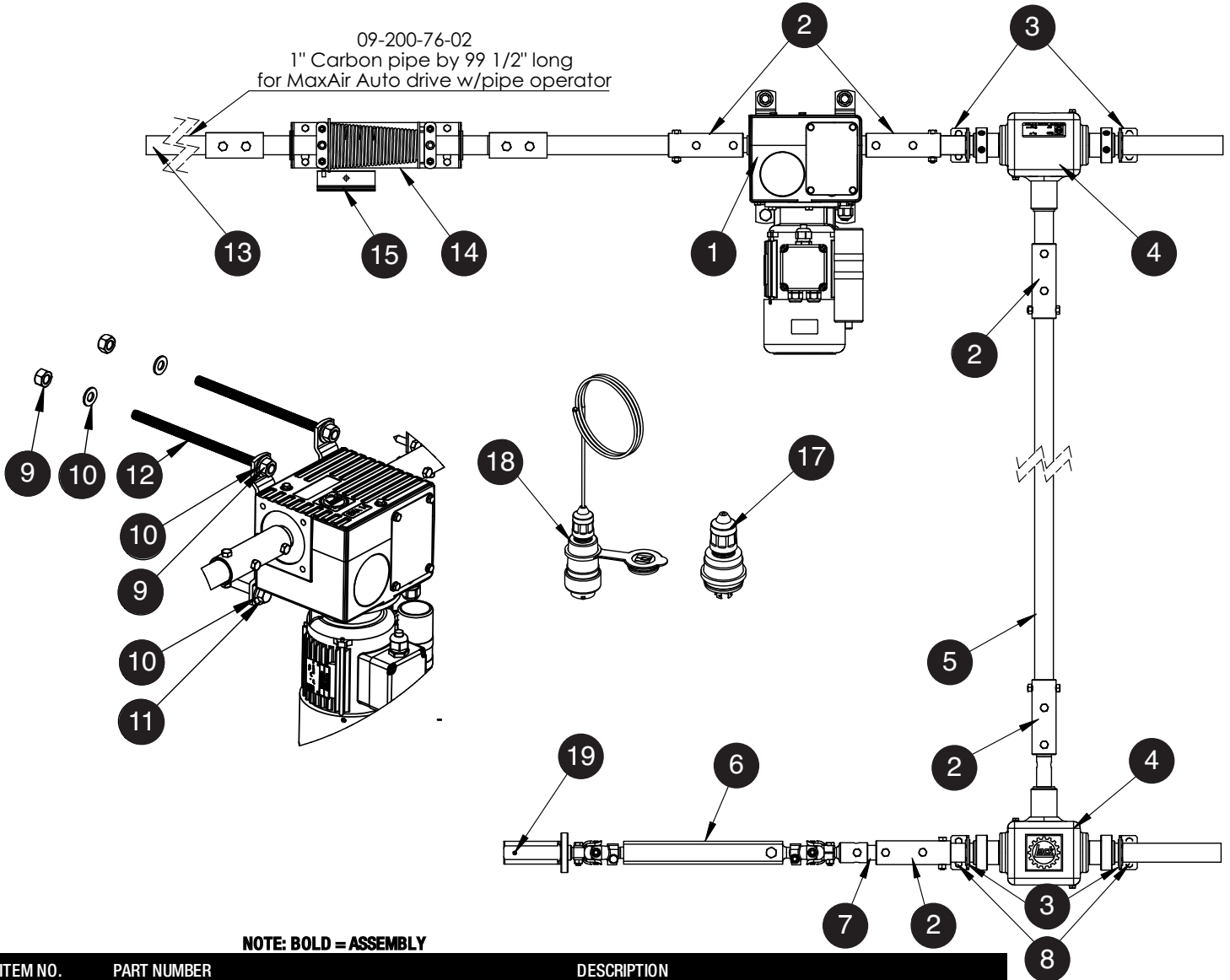

NOTE: BOLD = ASSEMBLY

ITEM NO.	PART NUMBER	DESCRIPTION
1	LDEWA12.2503	POWER DRIVE 250NM 3.8RPM WE06 240V 60HZ END20.40 A60 UL+CSA
2	LDBKS45.0634	BUSH COUPLING WE06 FOR TUBE 1" + SCREWS
3	LDELD12.9807	DRIVE TUBE BEARER, ANGLED LL=70MM STEEL BRONZE INSERT, ANGLED
4	LDKG032.1115	DEFLECTION GEAR UNIT 150NM 1:1 WE73 WITH LOCKING RING
5	09-200-79-01	1" CARBON PIPE BY 132" LONG FOR RAW DRIVE W/PIPE OPERATION
6	LDGKT04.0447	TELESCOPIC COUPLING 04 HL=0.40M >TUBE INSIDE 47MM
7	LDGKA06.0680	ADAPTER WE06 X 80MM
8	BZHLB142	1/4 X 2 HEX LAG SCREW ZINC
	09-200-76-10	LD MOUNTING KIT
9	NZHN12	1/2 - 13 HEX NUT GR5
10	WZPQ12	1/2" ZINC WASHER
11	BZHCS12312	1/2 - 13 X 3 1/2 HEX CAP LAG SCREW ZINC
12	TR1236C	1/2 - 13 THREADED ROD COARSE ZINC (PER FOOT)
13	09-200-76-02	1" CARBON PIPE BY 99 1/2" LONG FOR MAX AIR AUTO DRIVE W/PIPE OPERATION
14	LDSTR 22.7410	CABLE DRUM KIT UNIT 74/49mm, GROOVED WITH 4.8mm ROPE WE34mm
15	08-230-64-02	ALUMINUM LIFT BAR 4" WITH .3125 HOLE
16	09-200-76-01	1" CARBON PIPE BY 55" LONG FOR MAXAIR AUTO DRIVE W/PIPE OPERATION
17	09-200-76-40	PLUG, MALE END, 20A 125 250V, 26W74
18	09-300-76-01	FEMALE END OF SAFETY POWER CORD (WITH 10' CORD)
19	R31638	3/16" x 3/8" POP RIVET

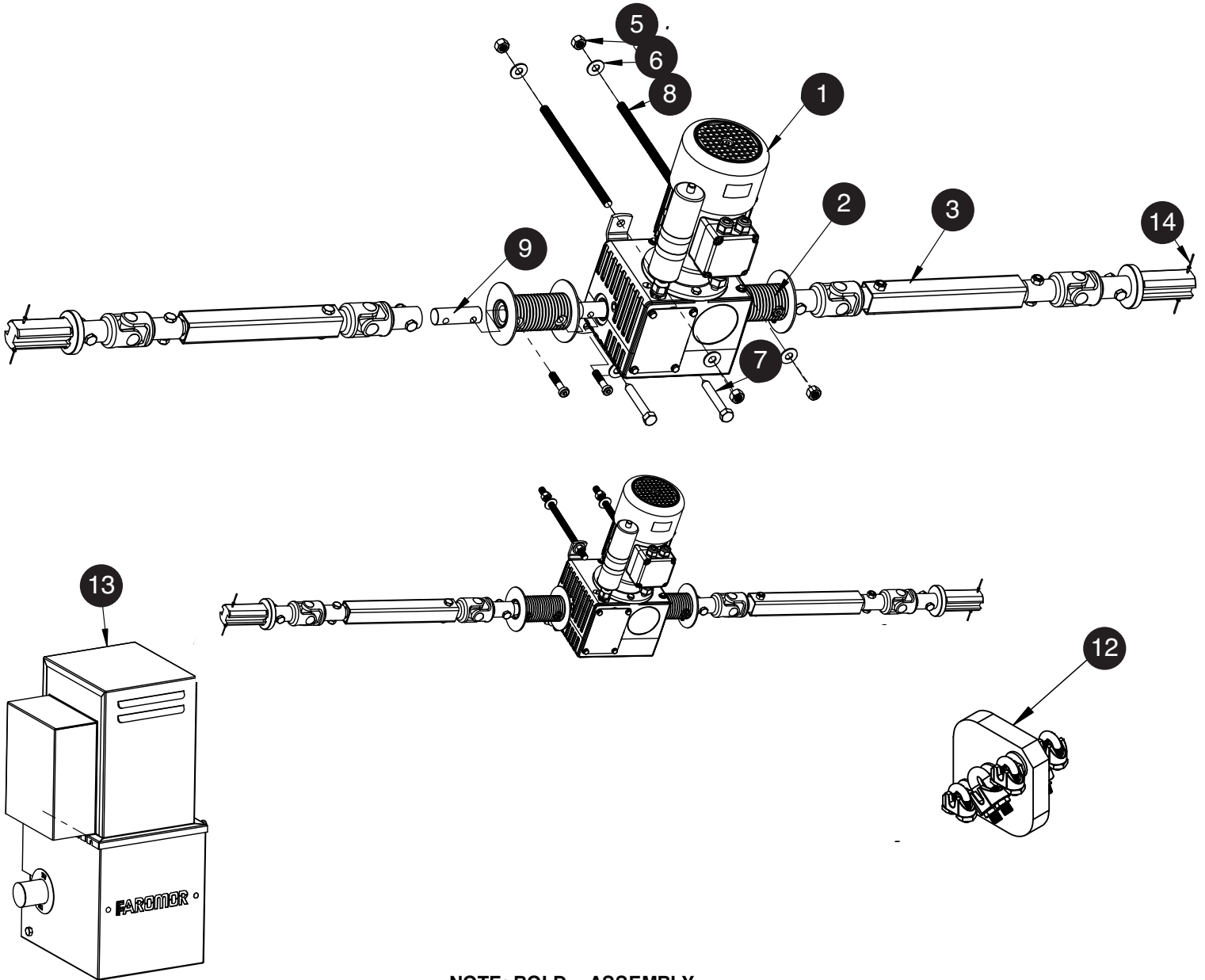

NOTE: BOLD = ASSEMBLY

ITEM NO.	PART NUMBER	DESCRIPTION
1	LDEWA12.2503	POWER DRIVE 250NM 3.8RPM WE06 240V 60HZ END20.40 A60 UL+CSA
2	LDATR06.5403	CABLE DRUM 54MM, GROOVED
3	LDGKT04.0447	TELESCOPIC COUPLING 04, HL=0.40MM->TUBE INSIDE 47MM
4	09-200-76-10	LD MOUNTING KIT
5	LZHN12	1/2"- 13 HEX NUT GR5
6	WZPQ12	1/2 ZINC WASHER
7	BZHCS12312	1/2"-13 X 3 1/2" HEX CAP LAG SCREW ZINC
8	TR1236C	1/2"-13 THREADED ROD COARSE ZINC (PER FOOT)
9	LDGKA06.0680	ADAPTER WE06X80MM
10	09-200-76-40	PLUG, MALE END 20A 125 250V, 26W74
11	09-300-76-02	FEMAL END OF SAFETY POWER CORD (WITH 10' CORD)
12	08-131-50	CABLE ANTI-TWIST PLATE ASSEMBLY
13	09-208-58	LD N.A. RAW SS COVER COMPLETE
14	R31638	3/16"X3/8" POP RIVET

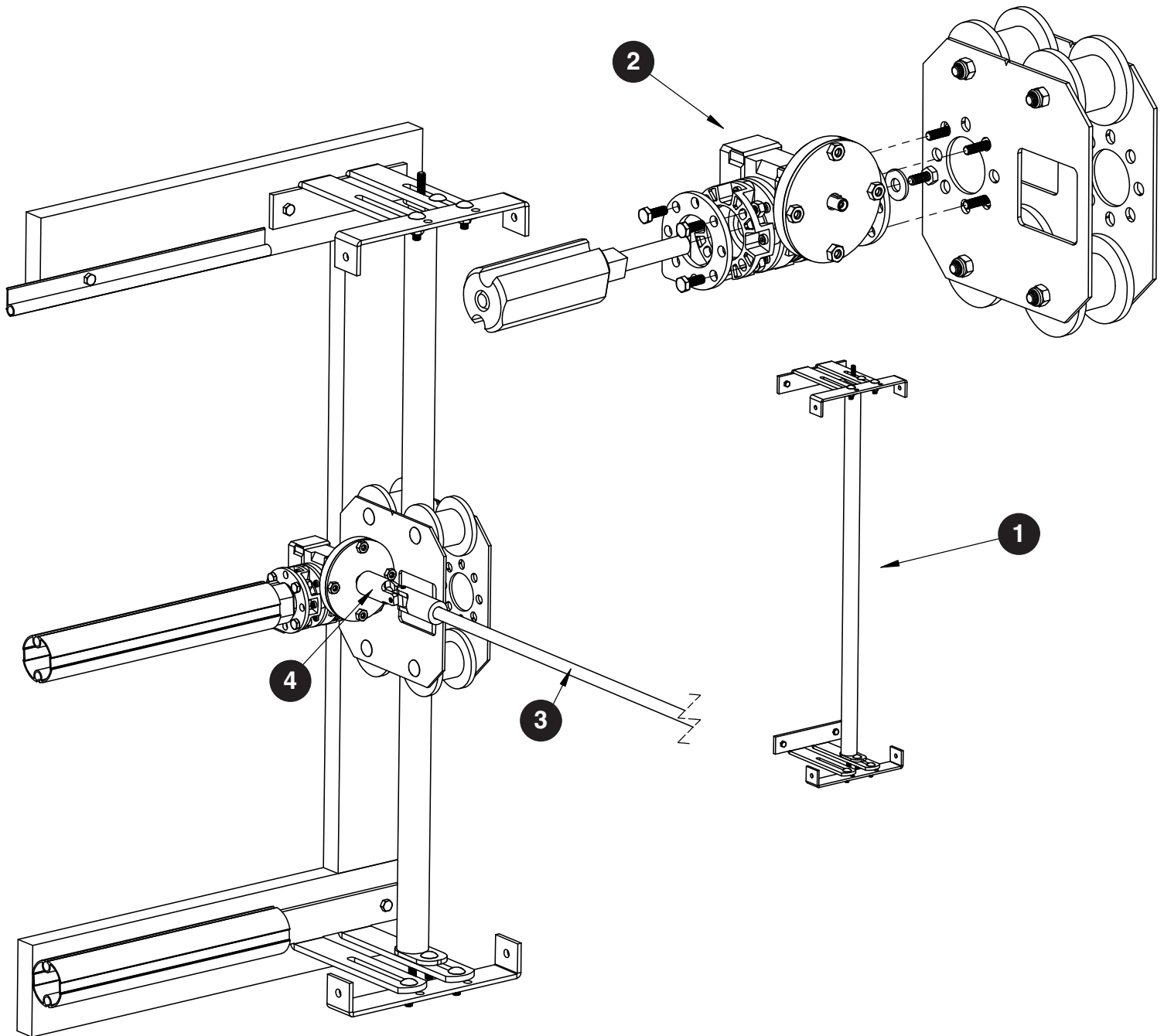

ITEM NO.	PART NUMBER	DESCRIPTION
1	08-230-56	1" GUIDE PIPE ASSEMBLY
2	08-230-57-01	HEAVY DUTY 28:1 MANUAL DRIVE ASSEMBLY
3	08-230-16-08	LONG HANDLE EXTENSION FOR ROLL-UP GEARBOX
4	08-230-16-10	UNIVERSAL HANDLE ADAPTER FOR BOTTOM ROLL-UP

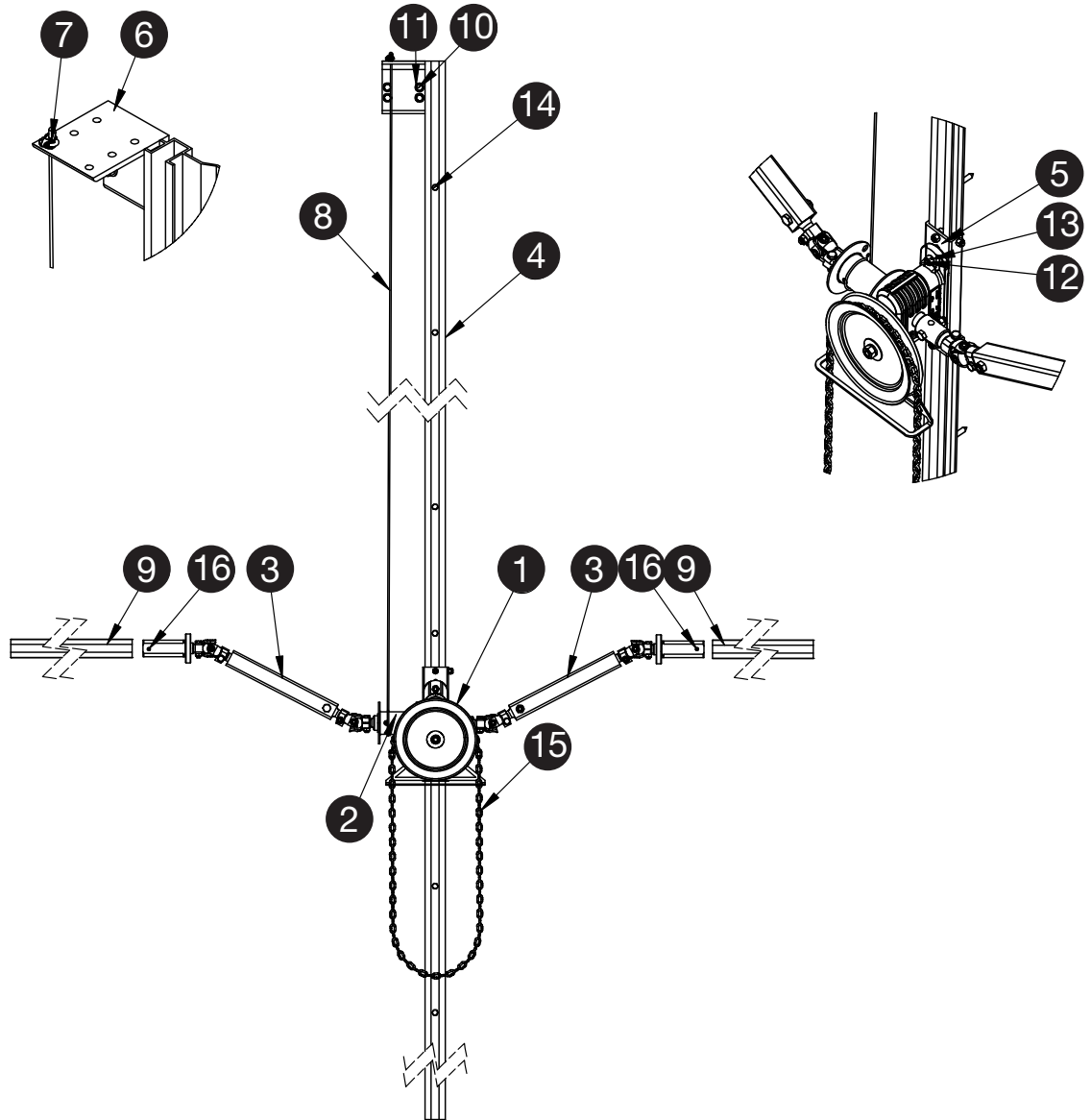

ITEM NO.	PART NUMBER	DESCRIPTION
1	LDWA53.0812	MANUAL DRIVE 120Nm 18:1, WE06,CHAIN DRIVE
2	LDATR06.5403	CABLE DRUM 54MM GROOVED
3	LDGKT04.0447	TELESCOPIC COUPLING 04, HL=0.40MM->TUBE INSIDE 47MM
4	LDWRZ01.0130	GUIDING PROFILE FOR 1 ROLLER CARRIAGE L=3.00M
5	LDWRZ10.0120	ROLLER CARRIGE EWA 10+12+14 60.5X27 5X27.5MM WITH SCREW
6	08-200-21-02	HEAVY WINCH MOUNT ANGLE
7	08-200-17-04	1/8" CABLE CLAMP
8	08-100-18	1/8" SS. CABLE
9	09-204-65-01	CURTAIN WEIGHT
10	BZHLB382	3/8" X 2" ZINC HEX LAG BOLT
11	WZPW38	3/8" ZINCE PLATE WASHER
12	BZHSCSM1030	M10-1.5X30 HEX SOCKET CAP SCREW ZINC
13	NZLNM1015	M10-1.5 NYLON INSERT LOCK NUT ZINC
14	BZHLB5162	5/16"X2" ZINC HEX LAG BOLT
15	LDHK96.0509	MANUAL CHAIN DIN 766,9.00M LONG
16	631638	3/16"X3/8 POP RIVET
*not shown	LDKA06.0680	ADAPTER WE06X08MM

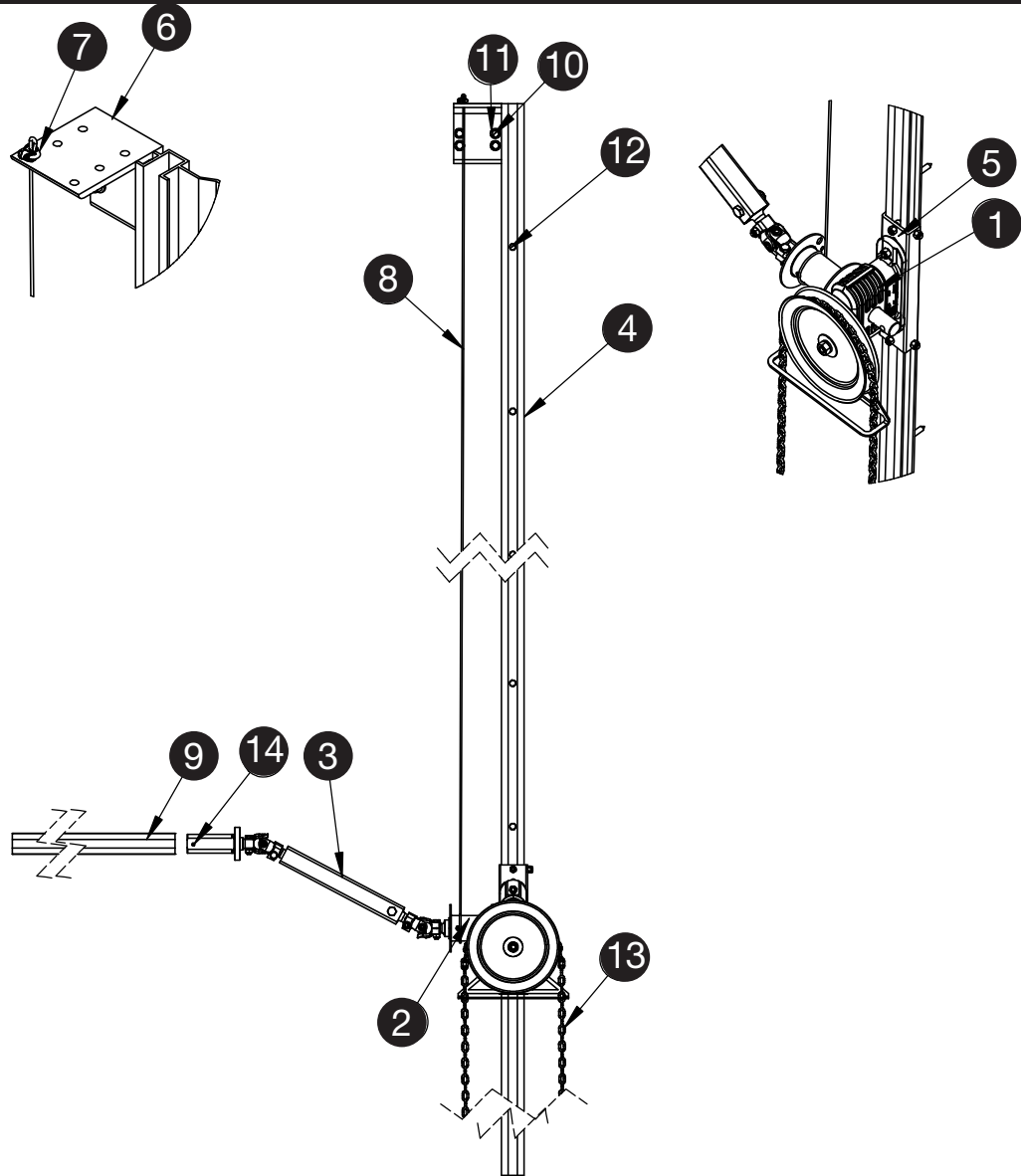

ITEM NO.	PART NUMBER	DESCRIPTION
1	LDWA53.0812	MANUAL DRIVE 120Nm 18:1, WE06,CHAIN DRIVE
2	LDATR06.5403	CABLE DRUM 54MM GROOVED
3	LDGKT04.0447	TELESCOPIC COUPLING 04, HL=0.40MM->TUBE INSIDE 47MM
4	LDWRZ01.0130	GUIDING PROFILE FOR 1 ROLLER CARRIAGE L=3.00M
5	LDWRZ10.0120	ROLLER CARRIGE EWA 10+12+14 60.5X27 5X27.5MM WITH SCREW
6	08-200-21-02	HEAVY WINCH MOUNT ANGLE
7	08-200-17-04	1/8" CABLE CLAMP
8	08-100-18	1/8" SS. CABLE
9	09-204-65-01	CURTAIN WEIGHT
10	BZHLB382	3/8" X 2" ZINC HEX LAG BOLT
11	WZPW38	3/8" ZINCE PLATE WASHER
12	BZHLB5162	5/16"X2" HEX LAG SCREW
13	LDHKU96.0509	MANUAL CHAIN DIN 766,9.00M LONG
14	R31638	3/16"X3/8" POP RIVET
*not shown	LDKA06.0680	ADAPTER WE06X08MM

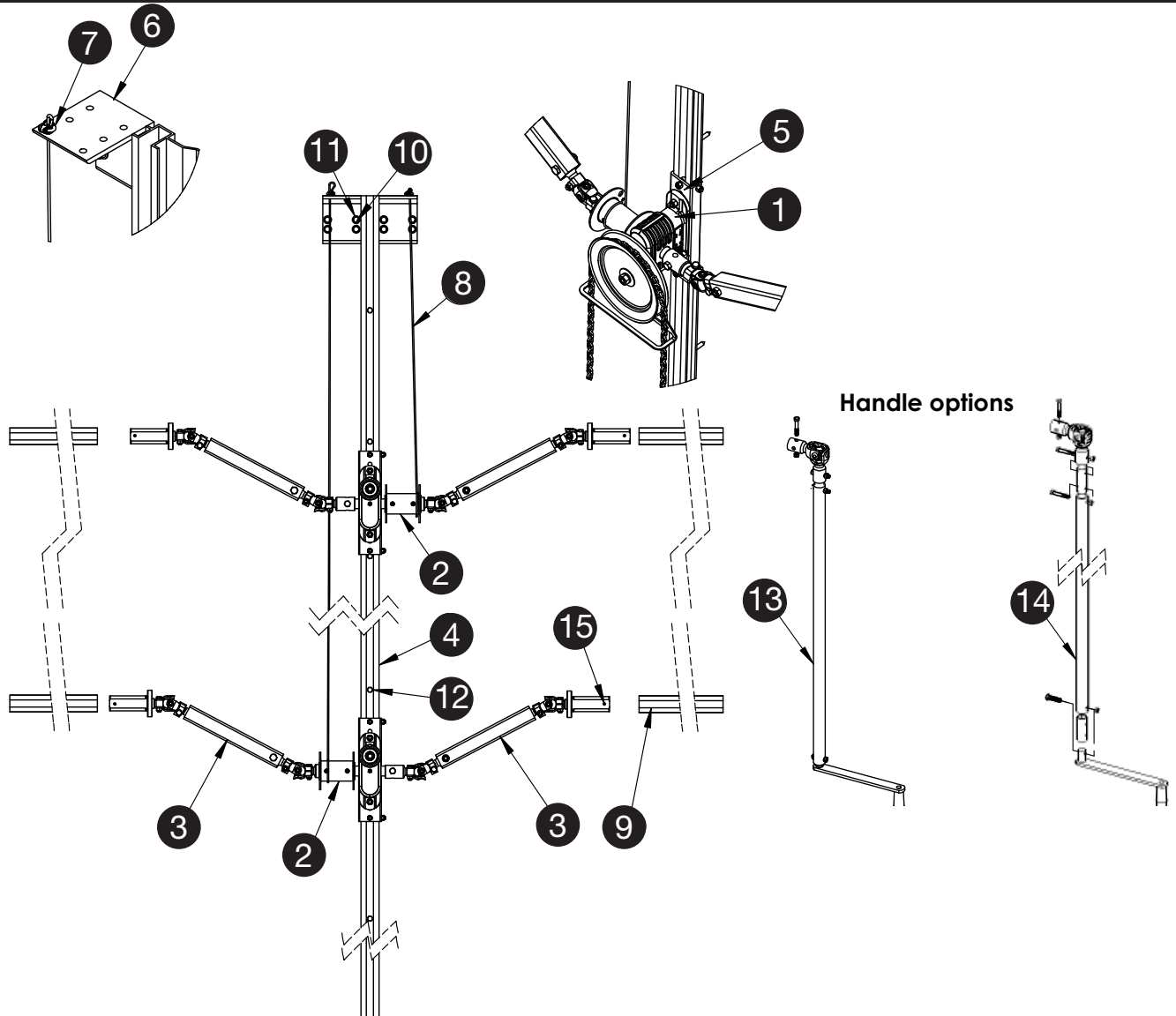

ITEM NO.	PART NUMBER	DESCRIPTION
1	LDHWA53.2012	MANUAL DRIVE 120Nm 18:1, WE06, WORM WE04
2	LDATR06.5403	CABLE DRUM 54MM GROOVED
3	LDGKT04.0447	TELESCOPIC COUPLING 04, HL=0.40MM->TUBE INSIDE 47MM
4	LDWRZ01.0130	GUIDING PROFILE FOR 1 ROLLER CARRIGE L=3.00M
5	LDWRZ10.0120	ROLLER CARRIGE EWA 10+12+14 60.5X27 5X27.5MM WITH SCREW
6	08-200-21-02	HEAVY WINCH MOUNT ANGLE
7	08-200-17-04	1/8" CABLE CLAMP
8	08-100-18	1/8" SS. CABLE
9	09-204-65-01	CURTAIN WEIGHT
10	BZHLB382	3/8" X 2" ZINC HEX LAG BOLT
11	WZPW38	3/8" ZINCE PLATE WASHER
12	BZHLB5162	5/16"X2" ZINC HEX LAG SCREW
13	08-334-26	MANUAL DRIVE HANDLE AND 36" EXTENSION
14	08-335-26	MANUAL DRIVE HANDLE AND 96" EXTENSION
15	R631638	3/16"X3/8" POP RIVET
*not shown	LDKA06.0680	ADAPTER WE06X08MM

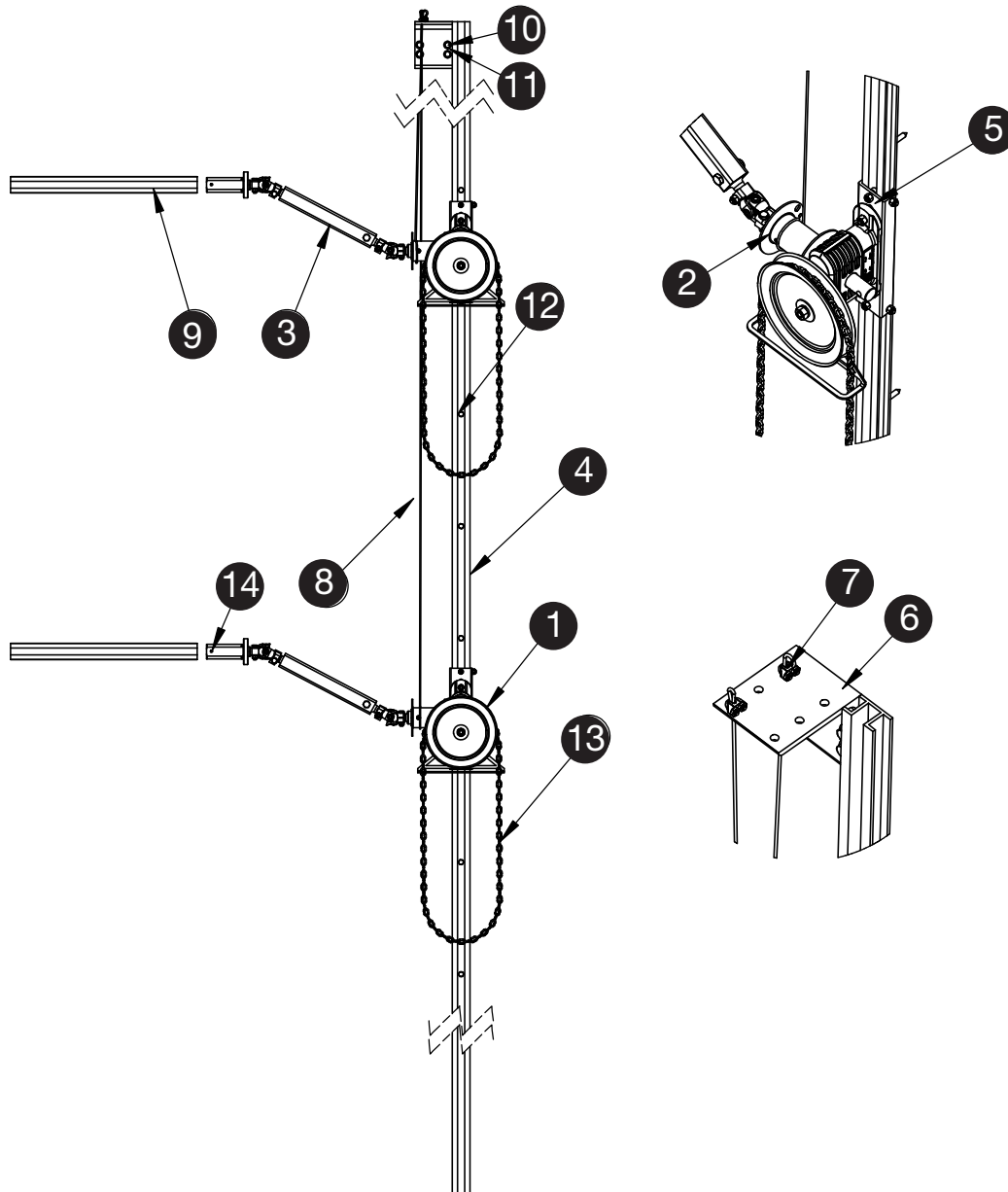

ITEM NO.	PART NUMBER	DESCRIPTION
1	LDWA53.0812	MANUAL DRIVE 120Nm 18:1, WE06,CHAIN DRIVE
2	LDATR06.5403	CABLE DRUM 54MM GROOVED
3	LDGKT04.0447	TELESCOPIC COUPLING 04, HL=0.40MM->TUBE INSIDE 47MM
4	LDWRZ01.0130	GUIDING PROFILE FOR 1 ROLLER CARRIGE L=3.00M
5	LDWRZ10.0120	ROLLER CARRIGE EWA 10+12+14 60.5X27 5X27.5MM WITH SCREW
	08-200-21-02	HEAVY WINCH MOUNT ANGLE
7	08-200-17-04	1/8" CABLE CLAMP
8	08-100-18	1/8" SS. CABLE
9	09-204-65-01	CURTAIN WEIGHT
10	BZHLB382	3/8" X 2" ZINC HEX LAG BOLT
11	WZPW38	3/8" ZINCE PLATE WASHER
12	BZHLB54162	5/16"X2" HEX LAG SCREW
13	LDHKU96.0509	MANUAL CHAIN DIN 766,9.00M LONG
14	R31638	3/16"X3/8" POP RIVET
*not shown	LDKA06.0680	ADAPTER WE06X08MM

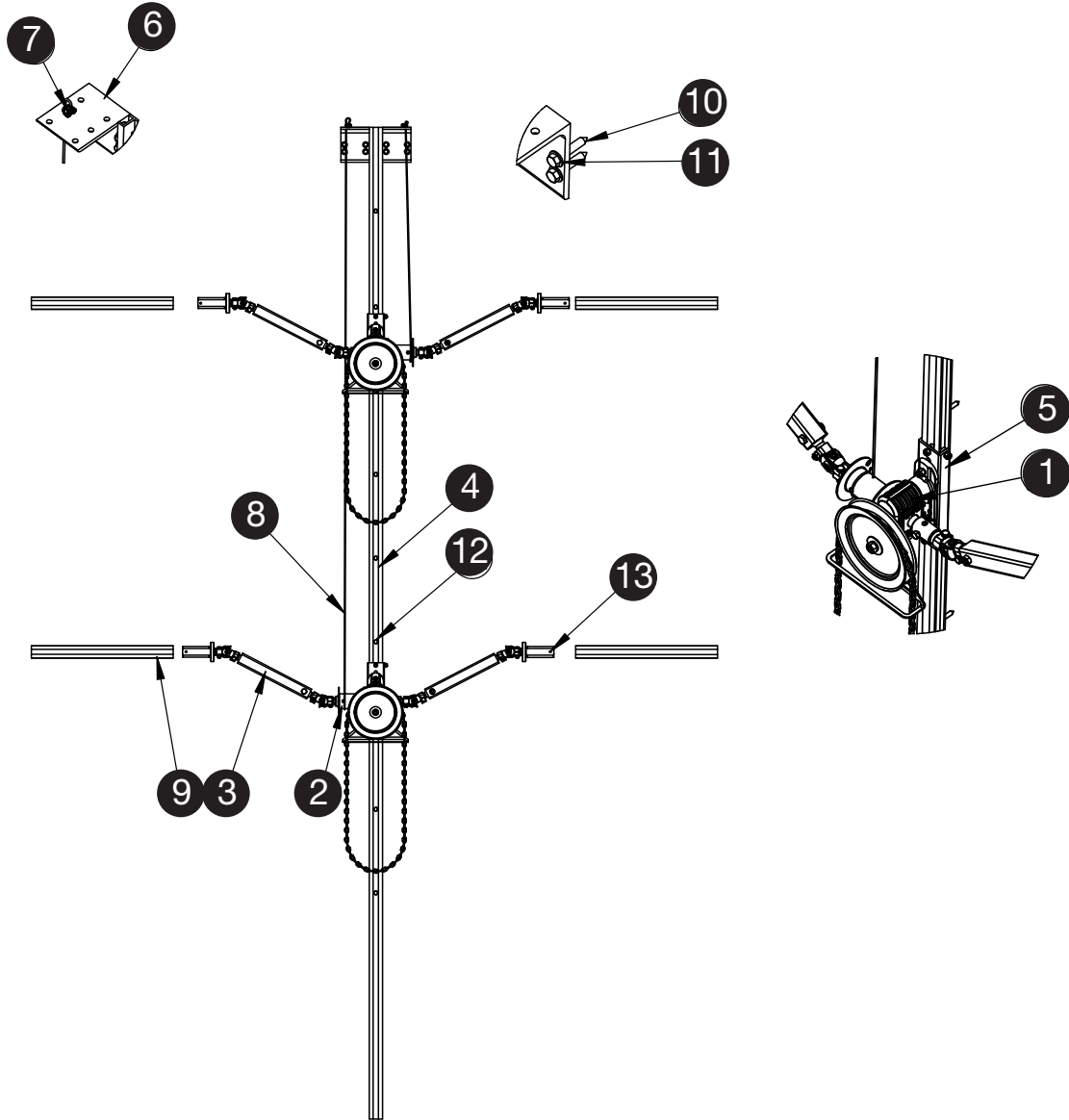

ITEM NO.	PART NUMBER	DESCRIPTION
1	LDWA53.0812	MANUAL DRIVE 120Nm 18:1, WE06,CHAIN DRIVE
2	LDATR06.5403	CABLE DRUM 54MM GROOVED
3	LDGKT04.0447	TELESCOPIC COUPLING 04, HL=0.40MM->TUBE INSIDE 47MM
4	LDWRZ01.0130	GUIDING PROFILE FOR 1 ROLLER CARRIGE L=3.00M
5	LDWRZ10.0120	ROLLER CARRIGE EWA 10+12+14 60.5X27 5X27.5MM WITH SCREW
6	08-200-21-02	HEAVY WINCH MOUNT ANGLE
7	08-200-17-04	1/8" CABLE CLAMP
8	08-100-18	1/8" SS. CABLE
9	09-204-65-01	CURTAIN WEIGHT
10	BZHLB382	3/8" X 2" ZINC HEX LAG BOLT
11	WZPW38	3/8" ZINCE PLATE WASHER
12	BZHLB54162	5/16"X2" HEX LAG SCREW
13	LDHKU96.0509	MANUAL CHAIN DIN 766,9.00M LONG
* not shown	R31638	3/16"X3/8" POP RIVET
*not shown	LDKA06.0680	ADAPTER WE06X08MM

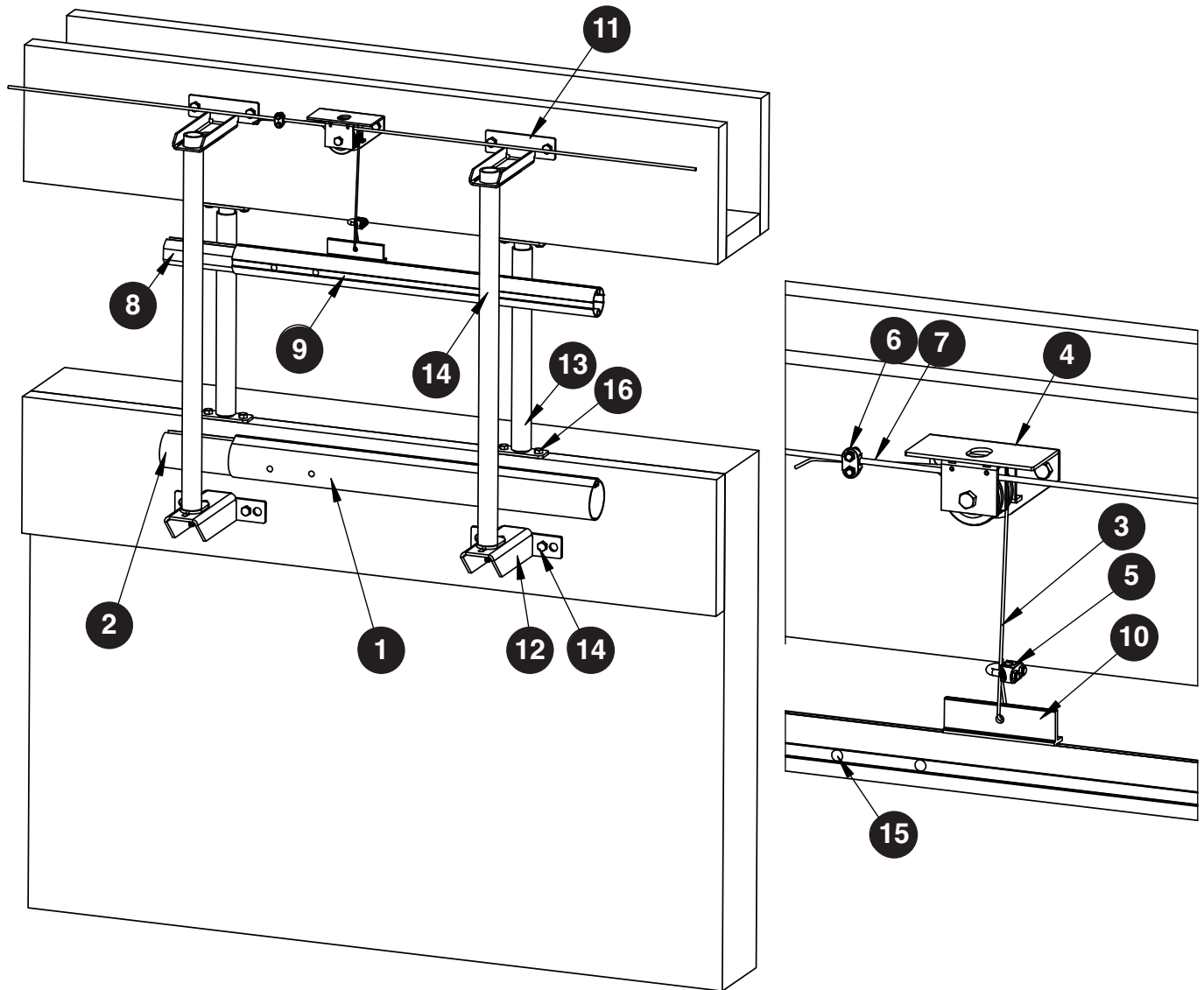

ITEM NO.	PART NUMBER	DESCRIPTION
1	04-204-02	3" ALUMINUM ROLLER TUBE
2	04-204-03	3" ALUMINUM ROLLER JOINER
3	08-100-18	1/8" S.S. CABLE PULL-UPS
4	08-131-14	HD DOUBLE CURTAIN PULLEY
5	08-200-17-04	1/8" CABLE CLAMP
6	08-210-24-04	3/16" CABLE CLAMP
7	08-210-24-05	3/16" S.S. MAIN CABLE
8	08-230-01-08	TUBE JOINER FOR 2" TUBING
9	08-230-01-09	ALUMINUM TUBE 2"

ITEM NO.	PART NUMBER	DESCRIPTION
10	08-230-01-10	ALUMINUM LIFT BAR
11	08-230-63	HD TOP WIND PIPE ADJUSTABLE BRACKET COMPLETE
12	08-230-58-02	HD BOTTOM WIND PIPE BRACKET W/SLOT
13	08-100-05	1" GALV. PIP - 1.315 OD x 12 GA
14	BZHLB382	3/8" x 2" ZINC HEX LAG BOLT
15	R316X34SF	SMALL HEAD ALUMINUM RIVET
16	BZHLB516112	5/16" x 1 1/2" ZINC HEX LAG BOLT

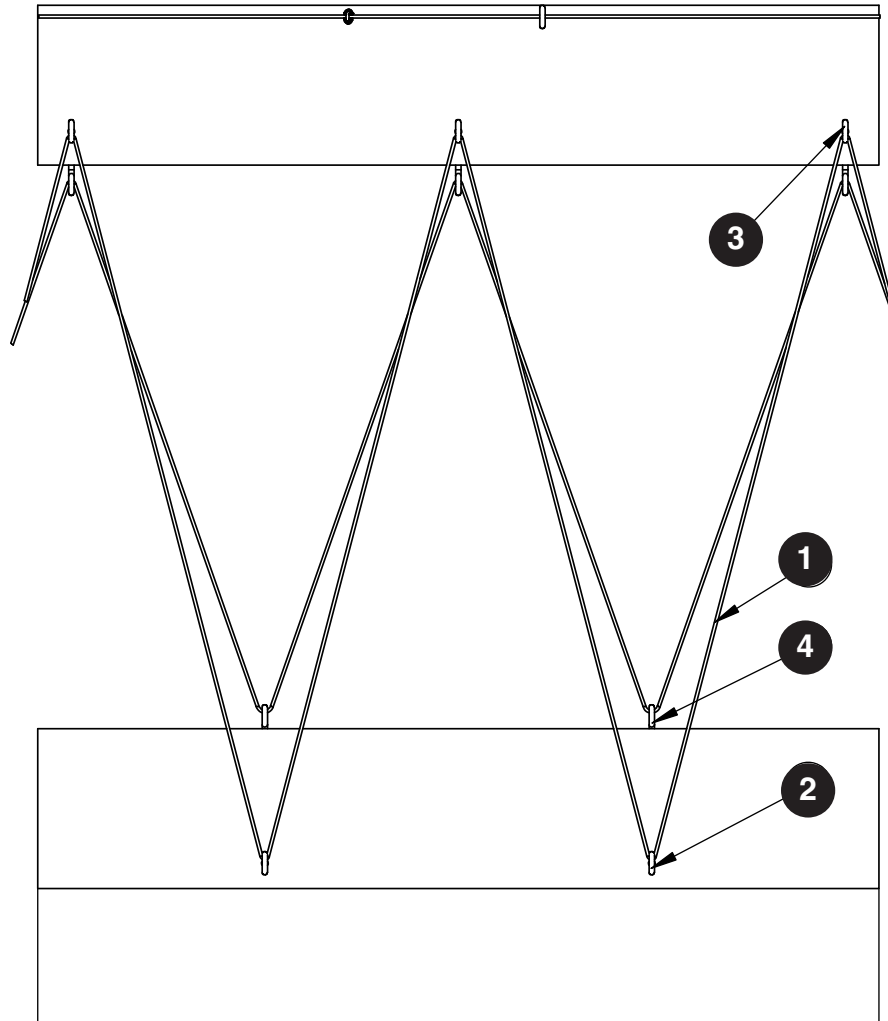

WIND ROPE REQUIRED FOR CURTAINS (SINGLE ROPE). (DOUBLE ROPE = LENGTH X 2)	
CURTAIN HEIGHT	CURTAIN LENGTH FACTOR X CURTAIN LENGTH = LENGTH OF ROPE
3'	2.5 X LENGTH
4'	3 X LENGTH
5'	3.5 X LENGTH
6'	4 X LENGTH
7'	4.5 X LENGTH
8	5 X LENGTH
9'	5.5 X LENGTH
10'	6 X LENGTH
11'	6.5 X LENGTH
12'	7 X LENGTH

ITEM NO.	PART NUMBER	DESCRIPTION
1	08-230-01-02	NYLON ROPE # 5
2	MEBG386	5154 BOTTOM EYEBOLT LAG THREAD 3/8" x 6"
3	MEBG38412	3/8" x 4 1/2 LAG SCREW EYE BOLT Z
4	MEBG2142625	5510-10 WPSE INSIDE SCREW EYE 1/4" x 2 5/8"

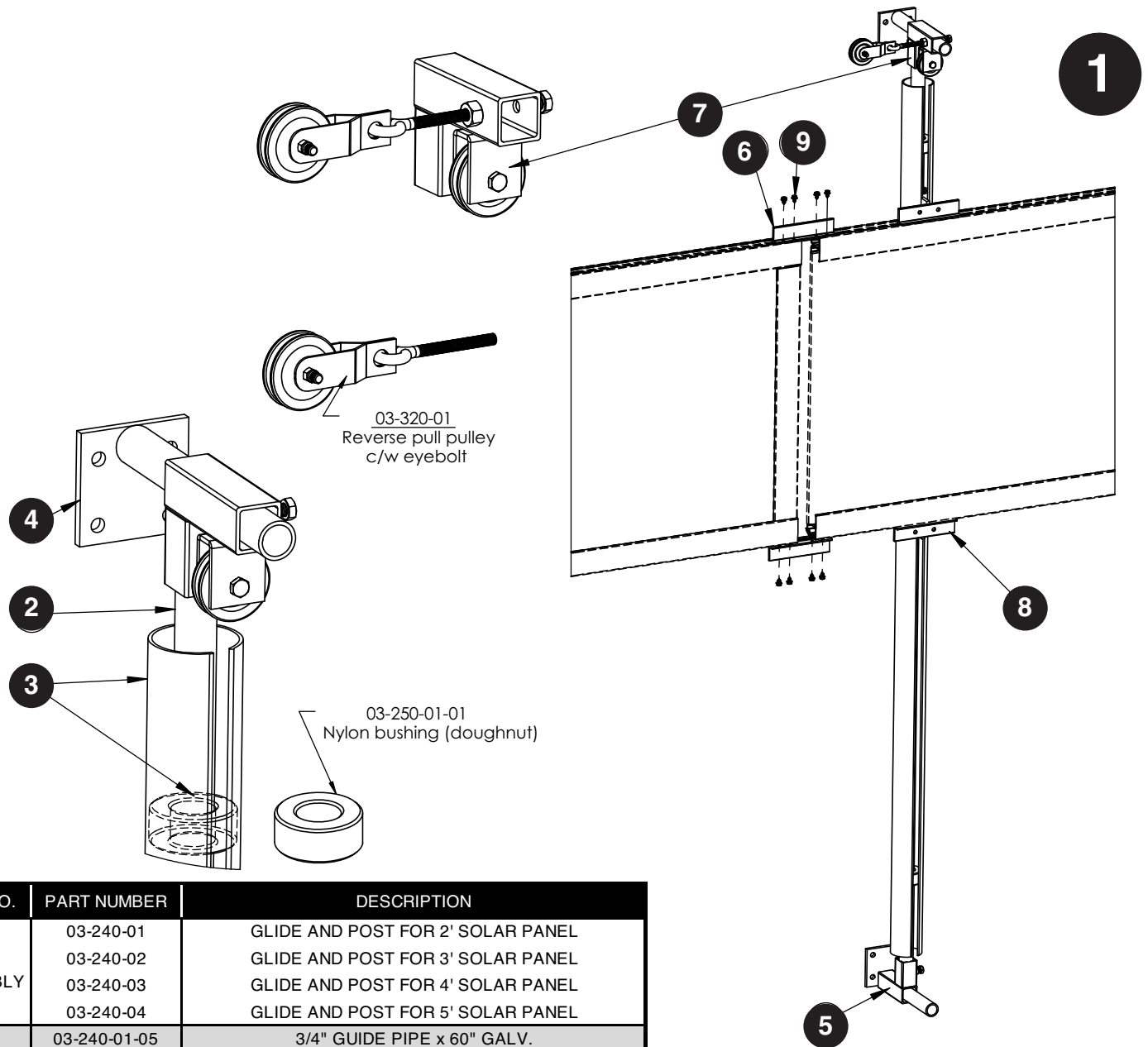

ITEM NO.	PART NUMBER	DESCRIPTION
1 ASSEMBLY	03-240-01	GLIDE AND POST FOR 2' SOLAR PANEL
	03-240-02	GLIDE AND POST FOR 3' SOLAR PANEL
	03-240-03	GLIDE AND POST FOR 4' SOLAR PANEL
	03-240-04	GLIDE AND POST FOR 5' SOLAR PANEL
2	03-240-01-05	3/4" GUIDE PIPE x 60" GALV.
	03-240-02-01	3/4" GUIDE PIPE x 84" GALV.
	03-240-03-01	3/4" GUIDE PIPE x 108" GALV.
	03-240-04-01	3/4" GUIDE PIPE x 132" GALV.
3	03-250-01	SOLAR GUIDE RAIN CAP FOR 2'
	03-250-02	SOLAR GUIDE RAIN CAP FOR 3'
	03-250-03	SOLAR GUIDE RAIN CAP FOR 4'
	03-250-04	SOLAR GUIDE RAIN CAP FOR 5'
4	03-210-01	TUBULAR SUPPORT FOR TOP & BOTTOM
5	03-230-01	BOTTOM ELBOW
6	03-240-01-06	ALUMINUM JOINER x 5"
7	03-260-01	REVERSE PULLEY ELBOW ASSEMBLY (COMPLETE)
8	03-340-01	SOLAR GLIDE
9	SSMS1034TAP	10-3/4" MACH SCR THRD FRM SACK A PAN SS

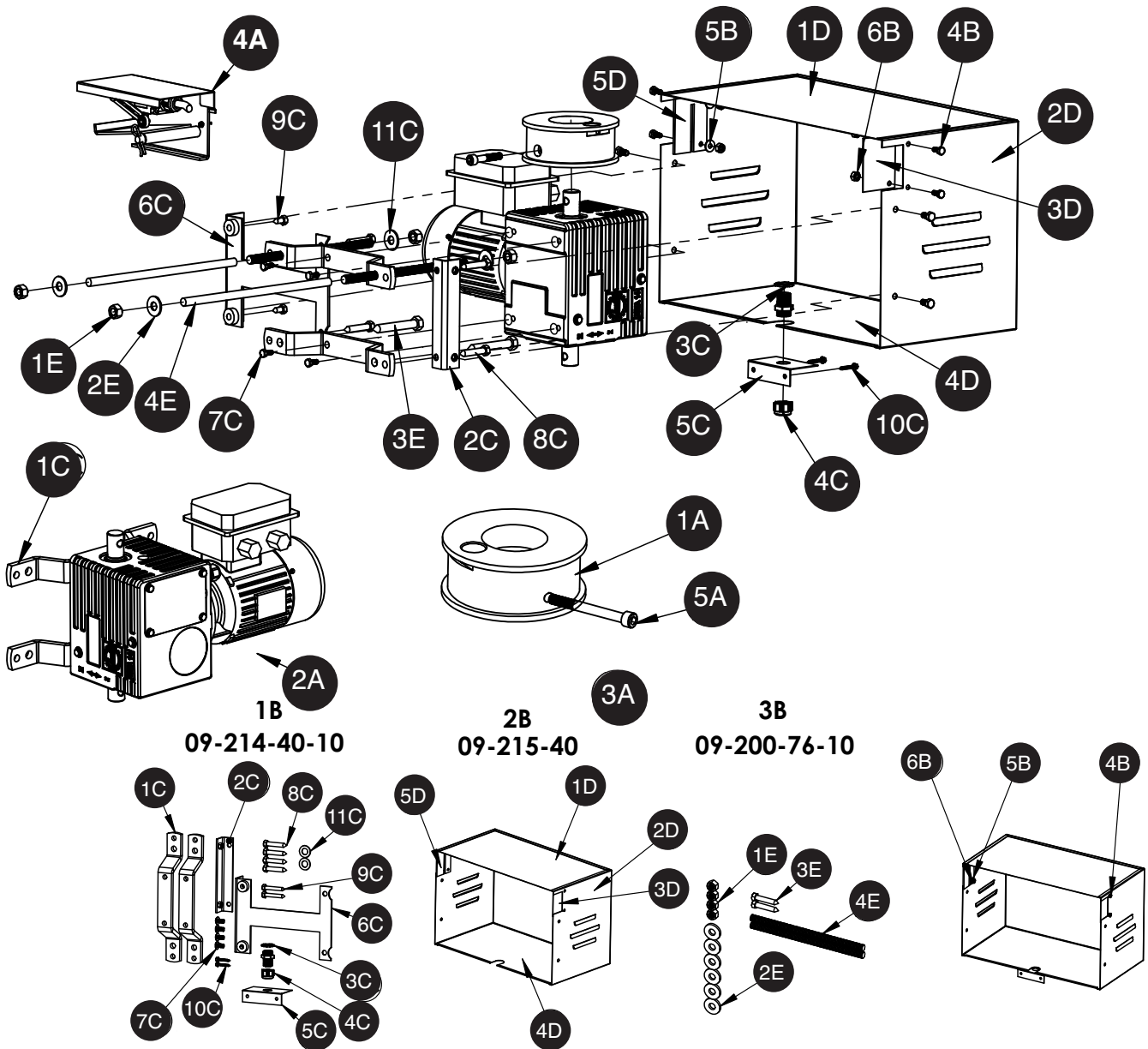

09-214-40-10 LD DRUM DRIVE MOUNTING KIT

ITEM NO.	PART NUMBER	DESCRIPTION
1C	09-204-40-02	LD DRUM DRIVE BRACKET
2C	09-324-40	HD DRUM WINCH MOUNTING BRACKET 'B' ASSEMBLY
3C	09-200-10-42	LOCKNUT, NYLON PG 16
4C	09-200-10-43	CORD CONNECTOR, 1/2" NPT .39 - .55
5C	09-224-40-06	LD DRUM WINCH COVER - S.S. WIRE PLATE COVER D
6C	09-214-40	LD DRUM WINCH COVER MOUNTING BRACKET ONLY
7C	BSHCS51658	5/16"-18 x 5/8" HEX CAP SCREW SS
8C	BZHLB382	3/8" x 2" ZINC HEX LAG BOLT
9C	BZHLB5162	5/16" x 2" ZINC HEX LAG BOLT
10C	WGRIP112GALV	WOODGRIP 1 1/2" GALVANIZED
11C	WZFLW12SAE	1/2" SAE FLAT WASHER ZINC

09-314-40 LD DRUM WINCH COVER AND BRACKETS

ITEM NO.	PART NUMBER	DESCRIPTION
1B	09-214-40-10	LD DRUM DRIVE MOUNTING KIT
2B	09-224-40	LD DRUM WINCH SS COVER ASSEMBLY
3B	09-200-76-10	LD MOUNTING KIT
4B	BSHCS1458	1/4"-20 x 5/8" HEX CAP SCREW SS
5B	WSFW14	1/4 FLAT WASHER SS
6B	NSHN14FF	1/4"-20 HEX NUT FIN FULL

09-200-76-10 LD MOUNTING KIT

ITEM NO.	PART NUMBER	DESCRIPTION
1E	NZHN12	1/2"-13 HEX NUT GR5
2E	WZPQ12	1/2" ZINC WASHER
3E	BZHCS12312	1/2"-13 x 3 1/2" HEX CAP LAG SCREW ZINC
4E	TR1236C	1/2"-13 THREADED ROD COARSE ZINC (PER FOOT)

09-224-40 LD DRUM WINCH SS COVER ASSEMBLY

ITEM NO.	PART NUMBER	DESCRIPTION
1D	09-224-40-01	LD DRUM WINCH COVER - SS TOP PLATE
2D	09-224-40-02	LD DRUM WINCH COVER - SS FRONT PLATE MAIN COVER
3D	09-224-40-03	LD DRUM WINCH COVER - SS BLANK PLATE
4D	09-224-40-05	LD DRUM WINCH COVER - SS BOTTOM PLATE
5D	09-224-40-07	LD DRUM WINCH COVER - SS BIRD BARRIER COVER

ITEM NO.	PART NUMBER	DESCRIPTION
1A	09-204-40-01	LD CABLE DRUM FOR AUTO WINCH
2A	09-304-40	LD POWER DRIVE FOR LD AUTO DRUM ASSEMBLY
3A	09-314-40	LD DRUM WINCH COVER AND BRACKET
4A	09-320-40	CABLE TENSION LIMIT SWITCH
5A	BZHSCSM10100	M10-1.5 x 100 HEX SOCKET CAP SCREW ZINC